

**ORIGINAL
OPERATING INSTRUCTIONS**

KTW
BIKE INDUSTRIES





KTM
BIKE INDUSTRIES

Table of Contents

General instructions	2	Wheels and tyres	39
Instructions for safe handling	2	General instructions	39
Before the first ride	4	Handling thru axles	39
Before every ride	4	Handling quick releases	40
After a fall	5	Tyre, rim, tube	41
Detailed view - Bicycle	6	Spoke tension and rim trueness	43
Detailed view - EPAC	8	Punctures	43
Intended use	9	Suspension elements	46
Categories	9	Definitions	46
Special restrictions	12	Suspension forks	47
Transporting luggage	13	Shocks	48
Rack	13	Maintenance of suspension elements	49
Using child seats	15	Suspension seat posts	50
Using trailers	16	Height-adjustable seat posts	50
EPAC drive system	17	Lighting	51
General instructions	17	Lighting on the EPAC	51
Standards, directives and conformity	17	Lighting on the bicycle	51
Safety instructions	18	Headset	52
Safety instructions for child EPACs	19	Checking the bearing clearance	52
Mounting the battery	19	Bottle holder	52
Cleaning and care	21	Particular properties of carbon material ..	53
Maintenance and repairs	21	Bicycle transport	54
Transport and loading	22	Bicycle transport by car	54
Range	23	Bicycle transport by train	54
Disposal	23	Bicycle transport by plane	54
Adjusting the bicycle	24	Bicycle equipment	55
Finding the right frame height	24	Bicycle helmet	55
Seat height and saddle position	25	Shoes and pedals	55
Handlebar height and stem settings	26	Maintenance and care instructions	56
Brake system	27	Cleaning and care	56
General instructions	27	Storage and safekeeping	56
Grip widths of brake arms	27	Maintenance and care intervals	57
Mechanical rim brakes	28	Recommended tightening torque	58
Hydraulic rim brakes	29	Warranty and guarantee	60
Disk brakes	30	Frame, frame kits and rigid forks	61
Coaster brakes	31	Wear parts	62
Propulsion	32	Frame engraving	62
General instructions	32	Handover certificate	63
Bottom bracket and cotterless right crank	32	Bicycle registration document	64
Derailleur gears	33	Inspection certificate	65
Hub gears	36		
Chain	37		
Belts	38		
Checking the functions	38		

General instructions

Congratulations! You have made a good decision by buying this quality bicycle made by KTM. We are convinced that your new bicycle will do more than just satisfy your expectations in regard to functionality, design and quality. All of our bikes are manufactured using premium materials and state-of-the-art technology and come equipped with only the best components. Your bicycle was assembled by the KTM dealer and then subjected to rigorous functional tests.

Explanation of symbols:



DANGER: Indicates a clear and imminent danger. The situation will lead to death or serious injury if it is not averted.



WARNING: Indicates a possible imminent danger. The situation may lead to death or serious injury if it is not averted.



NOTE/CAUTION: Indicates a possibly damaging situation. Your bicycle or its surroundings may be damaged if the situation is not averted.

Read these original operating instructions carefully. Please contact your KTM dealer if you do not understand them completely. All bicycles equipped with an electric drive system are referred to in this manual as EPAC (Electrically Power Assisted Cycles). Please read the EPAC supplement to the original operating instructions before first use if you decided to purchase an EPAC. If you allow a third party to use the EPAC, you must ensure that this person has read these instructions completely before using the bicycle for the first time.

Only use your bicycle for its intended purpose. To learn more, refer to the chapter on "Intended use". Improper use can lead to material defects, severe accidents or falls.

We wish you a good ride at all times!

The Team from **KTM Fahrrad GmbH**

Instructions for safe handling



- Carefully read and remember all safety information and warnings contained in these original operating instructions and all component manuals supplied with the bicycle.
- Get your KTM dealer to make the bicycle ready for use. Expertise and special tools are always required for all adjustments, maintenance and care of your bicycle. Ask your KTM dealer to carry out all work.
- Also contact your KTM dealer if you have questions about safe operation and handling.

▪ **Always adhere to the applicable laws of the land.**

The bicycle must comply with the national laws and regulations if you wish to use it on public roads. Obtain precise information about the highway code in the individual country.

▪ **Make sure that your bicycle is in a safe operational condition.**

Read the following sections "Before your first ride", "Before every ride" and "After a fall". Many of the components fitted to your bicycle experience severe wear. Bring the bicycle to your KTM dealer for regular inspections – refer to the chapter on "Maintenance and care intervals".

▪ **Be aware of the danger posed by rotating components**

Brake discs, chainrings and wheels rotate during operation (during regular use and maintenance) and can cause serious injuries or even loss of limbs

- **Bicycle lubricants and care products**

Please note that lubricants have been pre-applied to certain components of your bicycle. Lubricants and care products may have properties that are hazardous to health. Make sure that you obtain detailed information about the properties and safe use of the product in question. Avoid direct skin and eye contact and ingestion or inhalation during use and maintenance and always wear personal protective equipment (eye and hand protection). Your KTM dealer will gladly advise you on suitable, safe lubricants and care products.

- **Practice riding your bicycle on safe terrain without much traffic before venturing any further.**

Familiarise yourself with all the functions of your bicycle before using it, especially the brakes and the shifting system. This also applies to your child.

- **Children's bikes**

Make sure that your child has understood all the information on safe use and handling of the bicycle. Make certain that your child wears a helmet.

- **Drive slowly at night and in poor visibility, and never without lighting.**

Head lights, rear lamp and reflectors are mandatory, as is riding the bicycle to suit the particular situation.

- **When using your bicycle, always wear clothing that is suitable for cycling, a tested bicycle helmet, protective equipment and suitable, sturdy shoes.**

The bicycle helmet should carry a test mark according to DIN EN 1078 – refer to the chapter on “*Bicycle equipment*”.

- **Choose a particularly anticipatory riding style, especially when travelling at higher speeds.**

Twice the speed = four times the braking distance. The wheels may block and the bicycle might tip forward, especially if you take fright or brake very suddenly. Anticipatory riding and careful, appropriate braking are essential.

- **Adjust your riding style to the prevailing circumstances.**

The braking distance is significantly longer in wet weather, and sudden blocking of the wheels might lead to a fall.

- **Make certain that the frame size and operating elements are adjusted to suit your size.**

An incorrect frame size may negatively affect the operability and controllability of your bicycle – for instance, you may be unable to operate the brakes properly. Refer to the chapter on “*Adjusting the bicycle*”.

- **Be considerate of other road users, pedestrians and children.**

Always anticipate that others may behave incorrectly. Ride considerately and do not endanger or provoke other road users.

- **It is prohibited to operate your mobile phone or to listen to music using headphones while riding your bicycle.**

Doing so might distract you and restrict your awareness of the environment.

- **Cycleways running parallel to the road present a particular source of danger.**

They may be overlooked by drivers turning into a corner.

- **Cross rail tracks and manholes with particular care to avoid falling.**

Cross rail tracks at a right angle when possible.

- **Be aware that you may be in the blind spot of other vehicles at intersections.**

This may lead to dangerous situations, especially due to turning motor vehicles.

- **Only use original KTM components for repairs and replacements.**

You are advised to use only original KTM components to replace parts of your bicycle, as they must fulfil certain characteristics. Contact your KTM dealer to select the right replacement components.

- **Always protect the habitat of plants and animals.**

Only ride on marked tracks and roads. Avoid meadows and fields, and on no accounts cross bodies of water. Make sure you adapt your off-road speed to your driving skills.

- **Do not make any adjustments to the brakes or shifting system while riding the bicycle.**

This considerably increases the risk of a fall.

- **Never take anyone else on the back of your bicycle.**

This does not apply to small children travelling in a special child seat. The additional weight carried must be included in the maximum permissible weight. Not all bicycle frames are designed to carry child seats. Overloading the bicycle frame may cause it or its components to deform or break.

- **Never ride your bicycle freehand.**

This is extremely dangerous, as you can easily lose control of your bicycle.

- **Never ride your bicycle when under the influence of drugs, alcohol or medication or when you are fatigued.**

This is extremely dangerous, as you can easily lose control of your bicycle.

Before the first ride

1. Do not exceed the maximum load-bearing capacity of your bicycle and its components. Your bicycle was designed exclusively for the use described in the chapter on "*Intended use*".
2. Adhere to the maximum permissible weight (bicycle + rider + luggage) for which your bicycle was designed – refer to the chapter on "*Intended use*".
3. Familiarise yourself with how the brakes work before riding your bicycle for the first time. Check which brake lever operates the brake on the front or rear wheel – refer to the chapter on the "*Brake system*".
4. You must have understood how the gear shifting system works – refer to the chapter on "*Propulsion*".
5. The handlebars and saddle height must be adjusted to your size – refer to the chapter on "*Adjusting the bicycle*".
6. If your bicycle has clipless pedals, it is advisable to experiment with how to lock your shoe to the pedal and then release it again while the bicycle is stationary – refer to the chapter on "*Bicycle equipment*".
7. Ask your KTM dealer to make all adjustments to the suspension elements immediately after purchasing the bicycle. Incorrectly adjusted suspension elements may negatively affect riding behaviour and can therefore present an elevated safety risk. It may also damage the suspension elements or the frame – refer to the chapter on the "*Suspension elements*".

Before every ride

Your bicycle was tested several times during the production process and then given a final inspection by your KTM dealer. It is nonetheless possible that changes may have occurred on your bicycle during transport or as a result of manipulation.

1. Visually check all mounting screws. The bicycle must now show any mechanical damage in the form of deep scratches, notches or fractures. You must not notice any unusual sounds that may indicate that the screws have not been tightened properly.
2. All quick releases or thru axles on the front and rear wheel, as well as on the seat post, must be firmly closed. Check these things also if the bicycle has been left unsupervised, even for a brief period.
3. Check the condition, trueness and air pressure of both tyres. Pinch the tyre with your thumb and forefinger to check for the right air pressure. If you have one, use a manometer to determine the pressure. Refer to the chapter on "*Wheels and tyres*" for the correct procedure.
4. First check whether the brakes are working properly with the bicycle in a stationary position. To do this, pull the brake arm towards the handlebars. On no accounts may the brake arm touch the handlebars. The thickness of the brake pads must be adequate to ensure safe braking.

Rim brake: The brake pads must be firmly connected to the brake. When maximum pressure is applied to the brake lever, the brake pads must engage at the correct position on the rim flank so that they do not touch the tyre. Tilting from the rim flanks towards the spokes must not be possible.

Hydraulic brake systems: There must be no leakage of brake fluid onto brake system components – refer to the chapter on the "*Brake system*".

5. The laws of the land must be adhered to in all cases if you participate actively in road traffic. Never ride the bicycle without lighting and reflectors – refer to the chapter on "*Instructions for safe handling*".

6. To check the headset, move the handlebars alternately to the left and right, which must be possible smoothly and without clearance. Press and hold the front brake and then apply sudden pressure to push the bicycle backwards and forwards. This must also be possible without clearance or clicking sounds. The handlebars must not allow twisting relative to the front wheel – refer to the chapter on the “*Headset*”.
7. To check the suspension, lean on your bicycle and see whether the suspension elements move up and down in the usual way – refer to the chapter on “*Suspension elements*”.
8. You must fold up the bicycle stand before each ride to prevent a fall.
9. Ensure that the battery in EPACs is firmly seated in the holder provided and that the battery cover is securely closed. Remove the key before riding the bicycle.

After a fall



- On no accounts may you straighten components that were bent during a fall. There is an elevated risk of fracturing. This applies in particular to the fork, handlebars, stem, crank and pedals.
- The chapter on “*Particular properties of carbon material*” provides separate instructions on the handling of carbon components – read them carefully.

External influences, falls or accidents may damage components that are important for the safety of your bicycle. Make sure you adhere to the following points to avoid dangerous situations when riding your bicycle.

1. The wheels must still be correctly positioned in the frame and forks and show adequate trueness – refer to the chapter on “*Wheels and tyres*”.
2. The handlebars and stem must show the usual, correct alignment and the screws must still be tight. To check this, grip the front wheel between your knees and turn the handlebars alternately to the left and the right. On no accounts may the stem become misaligned during this process. If the handlebars turn when trying to depress the brake levers, the screw connection may have become loose – refer to the chapter on “*Adjusting the bicycle*”.
3. The chain must neither become dislodged from the chainrings or the rear sprocket. On no accounts may the front derailleur, rear derailleur and rear derailleur mounting have become bent. There is a significant risk of falling if the rear derailleur comes into contact with the spokes. Ask another person to grasp the saddle and lift the bicycle slightly while you operate the cranks to check whether the gear shifting system is working properly. Switch through all the gears during the check – refer to the chapter on “*Propulsion*”.
4. Push the saddle alternately upwards/downwards and try to twist it to check the screw connections between the saddle and the seat post. On no accounts may it be possible to twist or move the saddle. You can also use this method to check that the seat post is firmly mounted in the frame – refer to the chapter on “*Adjusting the bicycle*”.
5. Briefly lift the bicycle and then allow the tyre to bounce on the ground. Make sure that there are no unusual rattling sounds, which is a good way of identifying whether any screw connections are loose.
6. Ride slowly and carefully if the condition of your bicycle allows you to do so. Avoid sudden braking manoeuvres and rapid acceleration. On no accounts should you take risks, and discontinue your journey if necessary. After a fall, take your bicycle for an inspection by your KTM dealer as a precautionary measure.

Detailed view - Bicycle



Mountain Bike - Full Suspension (representative image)



Mountain Bike - Hardtail (representative image)

1 Top tube	7 Fork	13 Hub	19 Chain stay	25 Seat post
2 Headset	8 Front brake	14 Down tube	20 Rear derailleur	26 Seat post
3 Stem	9 Spokes	15 Cotterless right crank	21 Sprocket	27 Saddle clamp
4 Handlebars	10 Rim	16 Bottom bracket	22 Derailleur hanger	28 Saddle
5 Brake lever	11 Tyre	17 Derailleur (optional)	23 Back brake	29 Rocker
6 Head tube	12 Valve	18 Chain	24 Seat stay	30 Shocks



Road Bike (representative image)



Trekking - Onroad (representative image)

1	Top tube	7	Fork	13	Hub	19	Chain stay	25	Seat post	31	Head light
2	Headset	8	Front brake	14	Down tube	20	Rear derailleur	26	Seat post	32	Tail light
3	Stem	9	Spokes	15	Cotterless right crank	21	Sprocket	27	Saddle clamp	33	Racks
4	Handlebars	10	Rim	16	Bottom bracket	22	Derailleur hanger	28	Saddle		
5	Brake lever	11	Tyre	17	Derailleur (optional)	23	Back brake	29	Rocker		
6	Head tube	12	Valve	18	Chain	24	Seat stay	30	Shocks		

Detailed view - EPAC



EPAC - Full Suspension Mountain Bike (representative image)



EPAC - Trekking Onroad (representative image)

1 Top tube	8 Fork	15 Propulsion	22 Rear derailleur	29 Saddle clamp	36 Chain guard
2 Headset	9 Spokes	16 Drive unit cover	23 Sprocket	30 Seat post	37 Head light
3 Stem	10 Rim	17 Pedal	24 Derailleur hanger	31 Saddle	38 Tail light
4 On-board computer	11 Tyre	18 Cotterless right crank	25 Back brake	32 Battery	39 Racks
5 Handlebars	12 Valve	19 Bottom bracket	26 Seat stay	33 Battery lock	40 Stand
6 Brake lever	13 Front brake	20 Chain	27 Speed sensor	34 Shocks	
7 Head tube	14 Down tube	21 Chain stay	28 Seat post	35 Rocker	

Intended use

Bicycle frames and their components are always designed for different purposes and types of use. Each bicycle is intended for a certain purpose. KTM manufactures many categories of mountain bikes, road, racing and cyclocross bikes, trekking, touring, cargo and touring bikes as well as bikes for children and youths. Exceed the load-bearing capacity during using may damage the bicycle and its components. If the components are already damaged, they may even fail at a far lower load. It is therefore important that you use the bicycle only for its intended purpose. Neither the manufacturer nor the dealer is liable for damage resulting from failure to comply with the respective load limits or from misuse of the bicycle. In order to guarantee the long-term safety of your purchased product, it is imperative that you adhere to the operating, maintenance and servicing instructions specified by the manufacturer in the instructions for use. To this end, familiarise yourself in particular with the chapters on "Maintenance and care intervals" and "Warranty and guarantee". The following section defines different categories, depending on all uses and load limits.

Categories

KTM Fahrrad GmbH uses categories 0-5 or EPAC categories E0-E5. They differ significantly, especially in regard to their intended use. The various categories are described on the following pages.

A sticker „Fig. 1/ Bicycle sticker“ on page 9 / „Fig. 2/ EPAC sticker“ on page 9 indicating the applicable category is attached directly to the bicycle, namely around the lower tube or seat post. This sticker also shows all the relevant data for your bicycle.

Compare the indicated category with these instructions to learn precisely which uses or load limits apply to your bicycle. The CE mark is also on this sticker for EPACs.

In the CE marking, the manufacturer declares, in accordance with the EU Regulation, "that the product complies with the applicable requirements laid down in Community harmonisation legislation concerning its affixing."

The category switches automatically to 2 or E2 if racks, fenders or chain guards are fitted to offroad models. This does not apply to "short fenders" („Fig. 3/ Representative image, short fender“ on page 9) that can be attached to the fork, frame or the saddle without a stay.

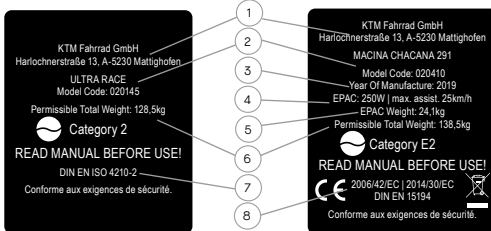

Fig. 1/9 Bicycle sticker



Fig. 2/9 EPAC sticker



Fig. 3/9 Representative image, short fender

No	Description
1	Manufacturer's name and address
2	Model designation and specific component number
3	EPAC's year of manufacture
4	Type of drive unit, continuous rated power of the drive unit, maximum pedal assist speed of the drive unit
5	Weight of the EPAC
6	Permissible maximum weight The bicycle's maximum permissible weight is the aggregate total of bicycle weight + rider + load + trailer and must not be exceeded under any circumstances
7	ISO 4210-2: Cycles - Safety requirements for bicycles
8	2006/42/EC = Machinery Directive 2014/30/EC = EMC Directive EN 15194 = Bicycles - electrically power assisted cycles - EPAC bicycles

Category 0 / E0

Bicycle type:	Children's bikes
	<p>Characteristics of category 0 / E0</p> <p>These bicycles are designed exclusively for children. On no accounts may bicycles in category 0/E0 be ridden by adolescents or adults. Children must never ride bikes unsupervised. In addition, children should always ride away from road traffic and other dangers or obstacles. They must also adapt their riding style to their skill levels.</p>
Approved use	Use of bicycles in category 0 / E0 is only permitted under parental supervision.
Prohibited use	Children must not ride their bicycles close to slopes, kerbs, steps, demolition sites, manhole covers or tracks used by motor vehicles.
Useful facts	 <p>The maximum adjustable saddle height (refer to the chapter on "Adjusting the bicycle") must not be less than 435 mm or more than 635 mm. The saddle height is the vertical distance between the ground and the upper edge of the saddle.</p>

Category 1 / E1

Bicycle types:	Road Race, Time Trial, Triathlon
	<p>Characteristics of category 1 / E1</p> <p>This is the bicycle category that is designed for use on paved or even roads. There may be unintentional loss of contact between the tyres and the road.</p>
Approved use	Exclusively for use on asphalt roads.
Prohibited use	Not suitable for offroad or use with racks or bicycle panniers.
Useful facts	Some countries may require the retrofitting of head lights, reflectors and fenders, etc. on public roads in order to comply with national laws. The safety equipment required for training purposes or competitions is supplied for bicycles in category 1/E1. It must be checked regularly and repaired by the user or specialist when necessary. The manufacturer and specialist dealer are not liable for damage resulting from offroad use of a road bike, from overloading and from improper repair of defects.

Category 2 / E2

Bicycle types:	City, Trekking Onroad, Trekking Offroad, Cyclocross, Mountain Bike Casual
	<p>Category 2 / E2</p> <p>This is a category of bicycles which includes intended uses described for categories 1 / E1, as well as for paved country roads, gravel paths and stretches with moderate ascents/descents. They can also be ridden on uneven terrain. Please note that the tyres may lose contact with the ground. Jumps must not exceed a height of 15 cm.</p>
Approved use	For asphalt roads, well-surfaced gravel paths and cycleways.
Prohibited use	Not suitable for offroad use, use as a mountain bike or for performing various freestyle tricks. Although some of these bicycles do have a suspension system, they are intended merely for comfort and are not suitable for rough terrain.
Useful facts	<p>Bicycles in this category are designed and equipped for compliance with the legal requirements of road traffic. They are also approved for use on country and forest paths where cycling is permitted. The safety equipment required for their intended purpose use is supplied. It must be checked regularly and repaired by the user or specialist when necessary.</p> <p>However, some of the bicycles in this category are not designed and equipped for compliance with the legal requirements of road traffic and must hence be considered sports equipment. If your bicycle is not equipped with active (rear lamps, head lights) and passive (reflectors) lighting devices, it must be retrofitted with components in accordance with the respective national laws and regulations before being used on public roads.</p>

Category 3 / E3

Bicycle types:	Mountain bike: Cross country, Marathon, Tour
	<p>Characteristics of category 3 / E3</p> <p>This is a category of bicycles which includes not only the intended uses described for categories 1 / E1 and 2 / E2, but also unpaved paths and technical areas. Jumps of up to 60 cm are permitted.</p>
Approved use	From easy to challenging terrain (small obstacles such as roots, stones and gullies on both loose and firm ground) during cross-country or competition events.
Prohibited use	Not suitable for any extreme forms of riding or jumps, e.g. free riding, enduro, downhill, freestyle tricks and similar.
Useful facts	These bicycles are not designed or equipped for use on public roads. Before the bike is used on public roads, it must be retrofitted with lighting and fenders, etc. to comply with national laws and regulations. The safety equipment required for offroad use is supplied. It must be checked regularly and repaired by the user or specialist when necessary.

Category 4 / E4

Bicycle types:	Mountain bike: Trail, All Mountain, Enduro
	<p>Characteristics of category 4 / E4</p> <p>This is a category of bicycles which includes intended uses described for categories 1 / E1, 2 / E2 and 3 / E3. This category is also suitable for restricted downhill use. Downhill riding is permitted up to a speed of 40 km/h, provided jumps do not exceed a height of 120 cm. Use of a bicycle under these conditions is strongly dependent on the experience and skills of the rider.</p>
Approved use	Bicycles in this category are more robust and solidly built than cross-country, marathon or tour mountain bikes. They are able to overcome more demanding terrain with larger obstacles and jumps due to the greater suspension travel.
Prohibited use	Areas of use that exceed the limits of the stated intended purpose.
Useful facts	These bicycles are not designed or equipped for use on public roads. Before the bike is used on public roads, it must be retrofitted with lighting and fenders, etc. to comply with national laws and regulations. The safety equipment required for offroad use is supplied. It must be checked regularly and repaired by the user or specialist when necessary.

Category 5 / E5

Bicycle types:	Mountain bike: Gravity, Freeride, Downhill
	<p>Category 5 / E5</p> <p>This is a category of bicycles which includes intended uses described for categories 1 / E1, 2 / E2, 3 / E3 and 4 / E4. The bikes are also designed for jumps of all kinds, with subsequent landings on sloping terrain and speeds of over 40 km/h. They are also approved for use in rough, inhospitable terrain. Use of a bicycle under these conditions is strongly dependent on the experience and skills of the rider.</p>
Approved use	Bicycles designed for the aforementioned use can be ridden in selective terrain. They are built to be extremely robust and offer significant suspension travel, which makes them ideal for overcoming obstacles. The components require particular care and cautious handling due to the extreme load to which they are exposed.
Prohibited use	Use beyond the personal limits of the rider. Be cautious and judicious in appraising your own abilities.
Useful facts	These bicycles are not designed for use on public roads. Before the bike is used on public roads, it must be retrofitted with lighting and fenders, etc. to comply with national laws and regulations. The safety equipment required for offroad use is supplied. It must be checked regularly and repaired by the user or specialist when necessary. Please be aware that overestimating your own abilities in this category can quickly lead to an accident with serious injuries or even death.

Special restrictions

Transport EPAC

The KTM Transport-EPAC "Macina Multi" is designed to carry heavy loads and can be retrofitted and extended with various components for transporting a wide variety of loads and child seats. Your KTM dealer would gladly advise you on other suitable equipment components. You must strictly adhere to all safety information and instructions that apply to the additional equipment components.

The maximum permissible weight is the aggregate total of rider + bicycle + luggage and must not be exceeded under any circumstances. The maximum weight of the additional load is equivalent to the maximum permissible weight minus the dead weight of the bicycle. The EPAC sticker provides information about the maximum permissible weight and the dead weight of the bicycle - refer to the chapter on „Categories“ on page 9. The information about weight distribution must be taken into account, which are addressed in more detail on the drop-down bar of the frame. The stickers attached for this purpose indicate the rack's load limits and the luggage sections of the frame. The luggage must be distributed in such a way that the rack's load limits and the load sections of the frame are not exceeded.

It is important to note that the maximum weight of the rider is lower if the maximum luggage weight is loaded („Fig. 1/ Representative image, additional load weight“ on page 12):

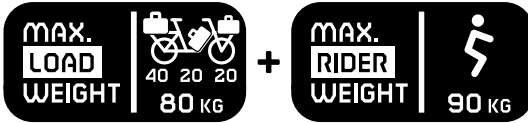

Fig. 1/12 Representative image, additional load weight

The weight of the luggage must be reduced if the maximum rider weight is reached in order to avoid exceeding the maximum permissible weight of the additional load („Fig. 2/ Representative image, additional load weight“ on page 12):



Fig. 2/12 Representative image, additional load weight

For more information, refer to the chapter on "Transporting luggage".

Transporting luggage





- Consult with your KTM dealer if you want to fit a rack, transport accessories, a child seat or a trailer.
- Heavy pieces of luggage should be stowed as far down as possible, as they extend the braking distance and change the riding characteristics (possible pendulum motion). This applies also to child seats and trailers. Go to a location without much traffic to practice riding (specifically with an empty child seat) and adjust your riding style suitably.
- Pay attention to the maximum permissible weight of your bicycle; do not exceed it in any event. The additional weight of a child seat and the load placed in a trailer without brakes are included in the maximum permissible weight. Refer to the section on “Categories” in the chapter on “Intended use”.
- Adjust the suspension elements and tyre pressure to suit the additional weight.
- Take care when tying up panniers that none of the mounting straps can become tangled in the spokes.

Racks



All racks installed by KTM comply with the EN 14872, i.e. EN ISO 11234 standards. In addition to the standard, you will find important information on the use of the rack engraved on the top of the rack, including the maximum load-bearing capacity and compatibility with child seats.



Fig. 1/13 Rack

Engraved symbol	Explanation
ISO 11243:2016	Applicable standard
max load 25 kg	Maximum permissible rack load
	The rack is not approved for mounting a child seat
NO CHILDSEAT	The rack is not approved for mounting a child seat
	The rack is suitable for direct mounting of a child seat using an adapter plate provided for this purpose - refer to the section “Using child seats”

The heavy-duty luggage racks for the Transport EPAC are approved for higher loads. For more information on safe use and weight distribution, refer to the chapter “Intended use” in the section “Transport EPAC”.

If a rack is retrofitted, please ensure that it has also been tested according to the aforementioned standards and is suitable for mounting on your particular bicycle frame. It is prohibited to mount cantilevered racks that are clamped to the seat posts of carbon frames or frames with full suspension. Adhere to any restrictions issued by the seat post manufacturer.

Besides transporting luggage with an ordinary rucksack, the following methods are permitted on the bicycle. Not all methods of transporting luggage are suitable for every bicycle for reasons of their design. Here you will find an overview of the most common methods of transporting luggage with panniers.

Rack bag	Handlebar bag	Lowrider pannier
		
<p>Rack bags are secured with lashing straps or, in the case of system racks, with a suitable adapter, depending on the type.</p>	<p>Handlebar bags are often attached to the handlebars using quick releases and are a practical way of storing valuables or camera equipment.</p>	<p>Special fork brackets can be fitted to attach lowrider panniers. They are suitable for transporting heavy items of luggage, as the low centre of gravity does not significantly affect the riding characteristics.</p>

Load your bicycle with suitable, robust and if possible waterproof panniers and make certain that their centre of gravity is as low as possible.

System racks

With just a few exceptions, all KTM bikes and EPACs are equipped with a system rack. System racks are used for the safe and convenient transport of luggage. Various accessory components, bags and baskets can be easily and simply attached to the bike or EPAC using system-specific adapters. Ask your KTM dealer which adapter is safe and compatible with your system rack.



- Take note that the components in the various system rack solutions are largely incompatible. Consult your KTM dealer for the selection, mounting and safe use of adapters, accessory components, bags and baskets.
- Read all instructions for the accessory components belonging to the system rack solution and make sure that you observe the safety information and instructions they contain.
- When using adapters, always pay attention to correct alignment, tight fit and correct locking.

The following system rack types are used for KTM bicycles and EPACs:

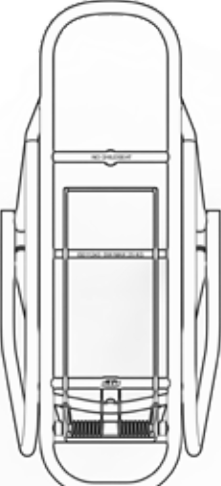
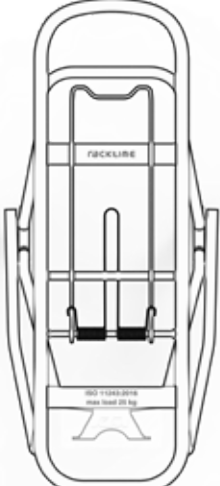
iRack1/iRack2	MonkeyLoad	Snap-it-1
		

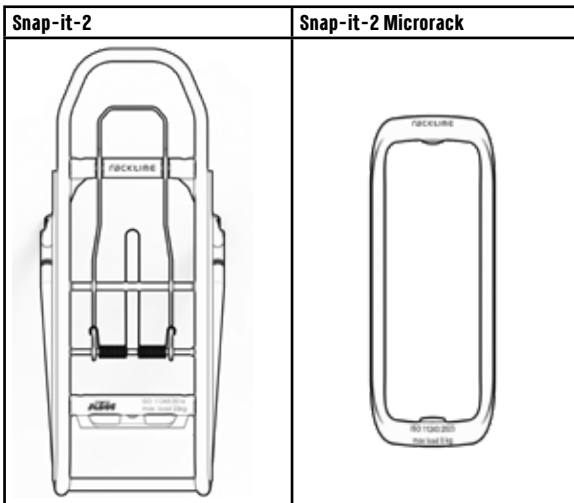

Combined system racks

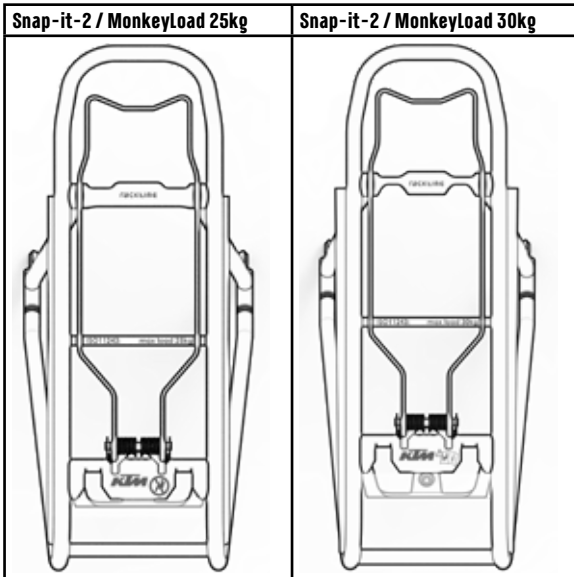

Using child seats



- With just a few exceptions, the mounting of child seats directly on the handlebars or on racks of any kind is prohibited, as this may break the components.
- Ask your KTM dealer whether your rack is suitable for a child seat.
- Make sure that your child is strapped into the child seat and that it is wearing suitable protective equipment like a bicycle helmet.
- The additional weight of a child seat extends the braking distance.
- Be particularly careful when placing your child in the child seat. There is a risk that your bicycle may tip over.
- Never leave your child unattended in the child seat of a parked bicycle. The bicycle may fall over, which might injure your child.
- Carbon frames and bicycles with full suspension are unsuitable for mounting a child seat.
- Child seats must not be mounted on bicycles equipped with a suspended seat post or saddle. Moving parts might injure your child.

Not every model by KTM Fahrrad GmbH is designed to accommodate a child seat. According to the chapter on “*Intended use*”, bicycles in the categories 1, 4, 5, E1, E4 and E5 are not suitable for the use of child seats. Carbon and full suspension frames are also unsuitable for mounting a child seat. You should therefore enquire with the child seat manufacturer or your KTM dealer to find out which model is suitable for your bicycle.

KTM Fahrrad GmbH has issued the following mounting approval for child seats:

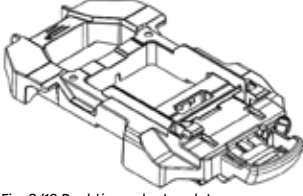
Mounting on the seat post	Mounting on the rack
 <p data-bbox="67 486 229 507">Fig. 1/16 Source BabyOK</p>	 <p data-bbox="504 486 720 507">Fig. 2/16 Racktime adapter plate</p>
<p data-bbox="67 529 488 587">The child seat is attached to the seat post of the frame using an adapter and a spring clip.</p>	<p data-bbox="504 529 1001 619">The rack must always be approved for mounting of a child seat – refer to the chapter “Racks”. Child seats must only be mounted using a special adapter plate from Racktime / Urban Iki.</p>

Using trailers



- If children are transported in a trailer, they must be strapped in and wear suitable protective equipment, i.e. a bicycle helmet.
- Adhere to the national laws and regulations when using bicycle trailers. Restrictions or specifications in regard to construction and lighting may apply.
- A pennant pole mounted on the trailer increases your visibility for other road users.
- It is prohibited to attach a trailer to bicycles in category 1 / E1 in accordance with the chapter on “*Intended use*”, as well as to bicycles with full suspension or a carbon frame.

Not every model by KTM Fahrrad GmbH is designed to accommodate a trailer hitch. You should therefore enquire with the trailer manufacturer or your KTM dealer to find out which trailer model is suitable for your bicycle.

KTM Fahrrad GmbH has issued a general approval for the following coupling systems:

- Low tow-arm attachment on the axle („Fig. 3/ Low tow-arm“ on page 16)
- Low tow-arm attachment on the drop out
- Centre tow-arm attachment on the rack „Fig. 4/ Centre tow-arm“ on page 16)

A general distinction can be made between trailers with brakes and those without. The maximum permissible trailer loads are 80 kg for braked trailers and 40 kg for trailers without brakes.

You must also adhere to national regulations, which in places stipulate significantly lower trailer loads. Take particular care if your bicycle has hub gears and you use a low tow-arm mount to connect a trailer to the rear wheel hub. The torque guard on the gear hub must be correctly mounted despite the screw connection for the trailer coupling. When connecting the trailer, make particularly certain that the clamping force is sufficient and that the trailer hitch guarantees the necessary torsional resistance at all times.



Fig. 3/16 Low tow-arm

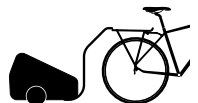

Fig. 4/16 Centre tow-arm

EPAC drive system

General instructions

All KTM bicycles that are fitted with an electric drive system are EPACs (**E**lectrically **P**ower **A**ssisted **C**ycles) as defined in EN 15194. Their main distinctive features compared to a bicycle without propulsion assistance are the installation of an on-board computer, battery and drive unit.

Make sure that you comply with the national laws defined in the applicable highway codes. Other conditions may apply in non-EU countries in Europe.

All KTM EPACs are designed for persons aged 14 and older. Child EPACs are an exception. All KTM EPACs are designed for persons aged 8 and older, provided they have received thorough instruction.

All components used in conjunction with the EPAC drive system are described in more detail in the enclosed component-specific "EPAC Supplement to the Original Operating Instructions". Please note that the enclosed documents also refers to EPACs as e-bikes, the motor unit as Drive Unit, the battery as PowerPack or PowerTube/CompactTube and the display as the on-board computer.



Exclusively original drive components and original batteries by the individual manufacturers are used in KTM EPACs. You should therefore use only original parts from the relevant manufacturer for retrofitting and replacement purposes. The use of third-party or unsuitable drive components and batteries can cause the battery to overheat, ignite or even explode. This would void all warranty and guarantee claims for the drive system.

EPAC drive components from different model years only show limited compatibility. Never try to install incompatible drive components by force. Doing so would place you and others at risk. It would void all warranty and guarantee claims relating to the drive system.

Under no circumstances may EPACs with fully-integrated down tube batteries be operated without the battery cover closed.

Please note removing a control panel or battery does not protect the bicycle against theft. The drive components can be used to operate your EPAC, even without the assist functions. You must therefore use a safe and tested bicycle lock to attach your EPAC to a fixed object at all times (bicycle stand, etc.). Your KTM dealer will gladly assist you in selecting the right bicycle lock.

Always remove the battery and keep it in a dry and under no circumstances unusually cold place (room temperature) if you will do not intend to use the EPAC for a longer period.

Standards, directives and conformity

The following EU regulations, standards and directives are used for the design and equipment of KTM EPACs:

- DIN EN 15194 / Bicycles – electrically power assisted cycles – EPAC bicycles
- Machinery Directive 2006/42/EC
- DIN EN ISO 4210-2 / Cycles – Safety requirements for bicycles – Part 2: Requirements for city and trekking, young adult, mountain and racing bicycles
- The national highway code in each country

The complete KTM EU Declaration of Conformity can be found on our website at <https://www.ktm-bikes.at/de/service/service-documents>. The complete Bosch EU Declarations of Conformity are available at the following Internet address: www.bosch-ebike.com/conformity.

Safety instructions



- Read the entire component-specific "EPAC – Supplement to the Original Operating Instructions" enclosed and pay particular attention to the chapter on safety instructions.
- The use of electronic components in a KTM EPAC may lead to additional hazards under certain circumstances. You must therefore read all safety instructions and keep them in a safe place for future reference. A failure to comply with the safety instructions can cause electric shocks, fire and/or severe injuries.
- Do not make any modifications or changes, neither to the hardware nor to the software. This can cause unpredictable, dangerous situations, accidents or falls that lead to injuries.
- Always charge the battery in a dry place and never close to easily flammable or combustible materials. Also keep metallic/electrically conductive objects away from the battery of your EPAC, as they may cause a short circuit if they touch the contacts of the battery and therefore increase the fire risk considerably.

▪ **Take care in connection with pacemakers and medical devices.**

This EPAC has been tested according to all valid and mandatory standards for EPACs. Nonetheless, this EPAC is not a special device that was manufactured according to medical requirements. In order to prevent possible malfunctions of your pacemaker or medical device, please consult your attending specialist or the manufacturer of the individual medical device before using the EPAC.

▪ **Emitted sound pressure level**

The A-weighted emission sound pressure level measured at the driver's ears is less than 70 dB(A)

▪ **Tuning**

Tuning means measures that are intended to increase performance or to exceed the speed limits of pedal assistance delivered by the individual drive system. This is achieved by changing the parameters or using retrofit tuning kits. Modifications of this kind are neither permitted nor recommended due to the strict legal conditions. These laws are in place to prevent dangerous situations. These modifications may also considerably increase wear on the drive system and components.

▪ **Do not ride the EPAC if the battery is dismantled**

The battery is used to power the lighting, so driving with the battery removed will affect how the lighting works. Failure to do so is an administrative offence and can lead to fines, loss of insurance or accidents and falls involving injuries.

▪ **Do not attempt to exceed the maximum pedal assist speed or modify the riding characteristics by manipulating the parameters.**

Manipulation is an administrative offence and can lead to fines, loss of insurance or accidents and falls involving injuries. It would void all warranty and guarantee claims.

Particular care must be taken in the following situations due to the high torque of the drive system:

- Motor power may take effect abruptly when starting at a high support level. Avoid putting pressure on the pedals if you are not seated properly on the bicycle or if you push off with one leg when setting off.
- Press the brakes for your own safety when getting onto the EPAC; this will prevent it from starting to move unintentionally.
- Press the brakes for your own safety while the bicycle is stationary (waiting); this will prevent the EPAC from starting to move unintentionally.

Safety instructions for child EPACs



- Read all the safety instructions and familiarise your child with their contents. So keep these operating instructions in a safe place for future reference. A failure to comply with the safety instructions can cause electric shocks, fire and/or severe injuries.
- Electric shock is a mortal danger. Cables must not be bent, compressed or damaged on sharp edges.
- The battery may ignite or even explode if its protective circuit and protective mechanism become damaged. This may present a mortal danger. Always remove the battery if you are performing maintenance, repair or cleaning tasks.

▪ **Never leave your child unsupervised when using and handling the EPAC.**

Familiarise your child with all functions before using the EPAC.

▪ **Give your child detailed instruction on how to use the EPAC.**

Incorrect use cannot otherwise be ruled out.

▪ **Child EPACs are only suitable for use on asphalted cycleways and roads.**

Use on the pavement is prohibited.

▪ **Never allow your child to handle or clean the EPAC with tools or bare hands.**

▪ **Before each journey with your child, make sure that all components are adjusted correctly and that the screw connections and quick release are closed tight.**

Refer to the chapter on "Before the first ride" and "Before every ride" in the original operating instructions.

▪ **Make certain that the frame size and operating elements are adjusted to the size of your child.**

An incorrect frame size may negatively affect the operability and controllability of the EPAC – for instance, the rider may be unable to operate the brakes properly.

▪ **Compared to a conventional EPAC, the following aspects were limited on the child EPAC to make sure that the safety of your child is guaranteed at all times.**

- The pedal assist speed was restricted to 20 km/h.
- The push aid function was disabled.
- The EPAC is initially in OFF mode when it is activated.
- The maximum permissible weight (rider + luggage) of a child EPAC is 50 kg.

Mounting the battery



- Read the enclosed "EPAC – Supplement to the Original Operating Instructions" on battery handling prior to removing the battery from the EPAC. Pay attention to the chapters on safety instructions in particular, operation, maintenance and service.
- Always treat the battery with care. Improper use may result in electric shock, leakage of toxic chemical substances, significant smoke, fire or even explosion.
- Ensure that the battery is firmly seated in the holder provided and that the battery cover is securely closed. Remove the key before riding the bicycle.

Removing and installing the battery

The battery can be removed from the top of the frame with most KTM EPACs. There is usually a handle or grip strap on the battery to facilitate removal. It is used exclusively for inserting and removing the battery and for carrying it by hand for short periods. It must not be used for prolonged transport or for suspended storage.



Fig. 1/ Handle

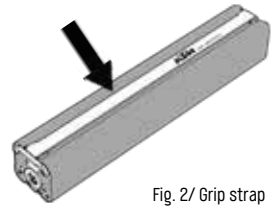

Fig. 2/ Grip strap

Proceed as follows to remove the battery:

1. Use the matching key to unlock the battery lock on the battery cover
2. The battery cover can either be folded back (step-through model) or completely removed from the down tube, depending on the model
3. The battery can only be removed from the frame. To do so, swivel the battery out of the battery holder on the lock side ① and pull it out of the electrical contact compartment ②. The lock side may be at the top „Fig. 1/ Handle” on page 20 or the bottom „Fig. 2/ Grip strap” on page 20, depending on the model
4. Then lift the battery carefully out of the cradle

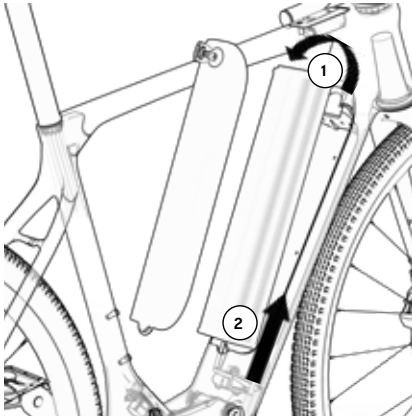

Fig. 3/ Lock side, top

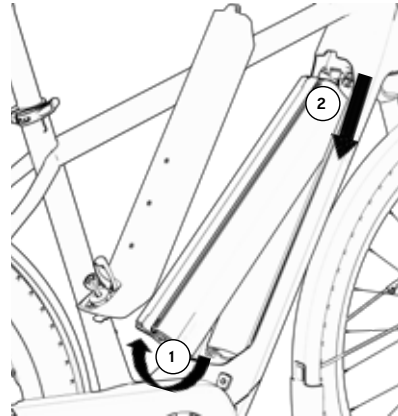

Fig. 4/ Lock side, bottom

Proceed in the opposite order to put the battery back in.

Original replacement batteries

The original batteries are equipped with different KTM-specific add-ons components, depending on the model. If an original replacement battery is used, it must be fitted with the matching mounting components to ensure that the battery is held firmly in the frame. For examples, see „Fig. 3/ Lock side, top” on page 20 and „Fig. 4/ Lock side, bottom” on page 20. Your KTM dealer will gladly assist you in selecting the right components.

Additional batteries for range extension

Additional range extenders can be fitted to the bottle holder eyelets on the frame or battery cover, depending on the equipment and frame version. Your KTM dealer will gladly assist you in selecting and installing approved additional batteries and charging cables. For information about the load-bearing capacity of the bottle holder eyelets, refer to the chapter “*Bottle holder*”

Cleaning and care

- **Never use a high-pressure cleaner or steam jet to clean your complete EPAC.**

The powerful water jet might damage the electrical drive components and the fine bushing on the other components. Use a soft sponge or a soft brush to clean your EPAC. As a rule, work with only a little water and keep water away from the electrical contacts. After cleaning, check the plug connections for moisture and allow them to dry before putting the bicycle back into operation.



Careful cleaning of your EPAC significantly extends the service life of the individual components. Clean your EPAC regularly as described above.

Maintenance and repairs

- **Only entrust your KTM dealer with repair and maintenance of the drive system.**

Unprofessional maintenance and repair may damage the EPAC.

- **Always remove the battery before maintenance and repair.**

There is otherwise a considerable risk of injury, as the system could start up due to mechanical actions such as the application of load to the chain or pedals, inadvertently pressing the push aid and similar.

- **Be careful not to fold or compress cables when performing maintenance or repair on the EPAC, and make sure that the cables are not damaged on sharp edges.**

Damaged cables present a life-threatening risk of electric shock.

- **Only use original KTM components, as well as original drive components and batteries, for repairs and replacements.**

You are advised to use only original KTM components to replace parts of your EPAC, as they must fulfil certain characteristics. You should also use only original drive components and batteries by the individual manufacturers. The use of third-party or unsuitable components may lead to breakage or failure that can cause accidents or falls with injuries. The use of third-party or unsuitable drive components and batteries can cause the battery to overheat, ignite or even explode. This would void all warranty and guarantee claims relating to the drive system. Contact your KTM dealer to select the right replacement components.

- **Bring your EPAC for its first inspection after 200 km.**

Screw connections may settle during the first kilometres of use. Ask your KTM dealer to check the spoke tension and all screw connections after the first 200 km. Refer to the chapter on "*Maintenance and care intervals*" in this regard.



Your EPAC will remain in a safe operational condition at all times if you adhere to the prescribed maintenance and care intervals. The service life of its components will also be extended.

- **Be aware that the components of your EPAC are exposed to greater wear. All original spare parts can be purchased from your KTM dealer.**

All components, especially the chain, sprocket and brake components, are subject to increased wear due to the additional exertion of force by the drive components and the greater weight of an EPAC. Shorter maintenance intervals must therefore be observed, compared to a conventional bicycle. Poorly maintained or worn components can lead to accidents or falls and then to injuries. Refer to the information in the chapter on "*Maintenance and care intervals*" in this regard.

- **Please note that the drive components show slightly elevated resistance when pedalling and emit a quiet travelling noise due to their technical design.**

Elevated freewheel resistance and a quiet travelling noise do not necessarily indicate a technical defect and are instead due to the technical design of the drive components. An increase in resistance or travelling noise during operation may indicate a lack of maintenance. Simply contact your KTM dealer.

- **You are urgently advised to make a note of the key number.**

The key number can be noted on the last page of the original operating instructions in the bicycle registration document and in the handover certificate. If you lose the key, you can use the key number to order a replacement from your KTM dealer.

Transport and loading



- Overloading may cause the EPAC components to deform or break.
- The battery may ignite or even explode if its protective circuit and protective mechanism become damaged. This may present a mortal danger. For this reason, remove the battery when transporting it by car.
- Attach a cap or another safety appliance to protect the battery contacts from unintentional short circuit.

Never take a passenger on your EPAC (exception: carrying a small child in a child seat).

Pay attention to the maximum permissible weight – refer to the chapter on “*Intended use*”.

- **Make sure that you remove the battery before transporting the EPAC by or in a car.**

Contact with liquids can cause heat, fire, explosion and smoke due to damage to the protective circuit and protective mechanism of the battery.

- **Adhere to the applicable regulations on hazardous goods when transporting the battery.**

Transporting an EPAC battery may be legally classified as a transport of hazardous goods. Familiarise yourself with the applicable regulations on hazardous goods before transporting the EPAC battery. Any violation of these regulations is an administrative offence and can lead to fines.

- **Exclusively use suitable bike carriers (roof or tail racks) to transport your EPAC by car.**

Not all bicycle bike are suitable for the safe transport of EPACs due to the position of the drive components, the special frame shape and the increased weight of EPACs. When transporting an EPAC, an unsuitable bike carrier may be damaged or break and therefore cause accidents. An unsuitable bike carrier may also damage the EPAC. After transporting the EPAC by car, check the plug connections for moisture and allow them to dry before putting the bicycle back into operation.

- **Be aware that driving characteristics may change significantly due to additional load.**

Pay attention to the maximum permissible weight for your EPAC during loading – refer to the chapter on “*Intended use*”. Keep the load symmetrical at all times.

- **Only use child seats that are suitable for mounting on your EPAC.**

Driving characteristics may change significantly due to additional load – refer to the chapter on “*Intended use*”. Your child should wear a tested child helmet.

- **Only use bicycle or child trailers that are suitable for attachment to your EPAC.**

The position of the drive components and the special frame form mean that not all bicycle or child trailers are suitable for attachment to the frame. You and your child may suffer accidents with very severe injuries if you use an unsuitable bicycle or child trailer. Your KTM dealer will gladly assist you in selecting a suitable trailer. Your child should wear a tested child helmet at all times.

Range

The anticipated range is calculated based on a maximum range value determined by KTM under real conditions (perfect riding conditions) and depending on the load status, taking into account the current consumption. This calculation enables the specification of a theoretical value. This value varies to a greater or lesser extent, depending on driving conditions. For instance, the range will be significantly smaller when travelling in a hilly or mountainous region. Please take note, therefore, that this indication can be used merely as a rough estimate for the achievable residual range.

The anticipated maximum range depends on a wide variety of circumstances. These factors include the selected support level, rider's weight, terrain, wind conditions, tyre pressure and ambient temperature. All range values indicated here refer to ideal conditions.

Optimal/ideal conditions are: even/flat terrain without head wind, 20°C ambient temperature, particularly narrow, treadless tyres, driver weight under 70kg.

Factors that affect the range

- 5. Route topography:** The energy required for navigating hilly terrain rises disproportionately compared to riding on level paths.
- 6. Selected support level:** Always select the support level to suit your needs and with care.
- 7. Battery charge:** Only a fully charged battery can guarantee the maximum range. So make sure that the battery is recharged before each use.
- 8. Weight and load:** The more weight that the bicycle carries (rider and luggage), the shorter the range.
- 9. Air pressure in the tyres:** The tyres offer significant potential. Insufficient pressure causes higher rolling resistance and therefore requires an extremely high energy input. The maximum permissible air pressure is printed directly on the sidewalls of the tyres. Tyres with rough, heavy tread require a great deal of energy. Switching to smooth, narrow tyres has a very favourable effect on the range.
- 6. Starting/accelerating from a stationary position:** Drive systems require considerably more energy when starting from a stationary position than when travelling continuously. Maintaining a constant speed or changing it only gently can improve the range. Avoid exerting sudden, jerky pressure on the pedals.
- 7. External influences/weather:** Managing Headwind requires an enormous expenditure of energy. Heat and cold can also drain the battery quickly.
- 8. Applied force:** The range will be very small if you rely exclusively on the drive system for power.
- 9. Shifting gears:** Use the gears actively just like with a normal bike. For instance, shift to a lower gear early enough when you are travelling uphill. The drive unit can only operate effectively and efficiently at an ideal cadence of 75 revolutions per minute. Slow pedalling leads to sudden assistance, causes the drive unit to overheat and will drain the battery very quickly.
- 10. Charging external software:** Charging external hardware such as smartphones or MP3 players using the charger port on the display can shorten the range accordingly.

Disposal

A used battery or defective electrical components must be disposed of properly.

Used batteries and electrical components, such as drive units, head lights, rear lamps and hub dynamos, must not be placed with household waste – please recycle them or return them to a KTM dealer. For detailed instructions concerning the disposal of EPAC components, refer to the enclosed Bosch instructions “EPAC – Supplement to the Original Operating Instructions”.



Adjusting the bicycle

Your posture when riding the bicycle is determined by the intended use, bicycle type and frame height. Some components are adjustable. For instance, the handlebars, stem, seat post, saddle, saddle and brake arms can be adjusted individually to suit your needs.



- Get your KTM dealer to make the bicycle ready for use. Expertise and special tools are always required for all adjustments, maintenance and care of your bicycle. Ask your KTM dealer to carry out all work.

Finding the right frame size

Using the correct frame size is essential for safe trips on your bicycle. The following table allows you to identify the right frame for the rider based on their body size.

BODY HEIGHT BODY HEIGHT	140-154 cm	155-164 cm	165-169 cm	170-174 cm	175-179 cm	180-184 cm	185-189 cm	190-194 cm	195-200 cm
MTB FULLY	S 38 cm		M 43 cm		L 48 cm		XL 53 cm		
MTB HARDTAIL MAC. GRAN (Man)	XS 32 cm	S 35-38 cm	M 42/43 cm	L 47/48 cm		XL 52/53 cm		XXL 57 cm	
ROAD (E)	XS 49 cm		S 52 (44.5) cm	M 55 (48) cm		L 57 (52) cm	XL 59 (55) cm		
TREKKING CITY/URBAN	XS 43 cm		S 46 cm	M 51 cm		L 56 cm	XL 60 cm		XXL 63 cm

KIDS/YOUTH KINDER/JUGEND

CLOTHING SIZE (Age) KLEIDUNGSGRÖSSE (Alter)	86 (1½+)	92 (2+)	104 (4+)	116 (6+)	128 (8+)	152 (12+)
WHEEL SIZE REIFENGRÖSSE	10"	12"	16"	20"	24"	26"

Note: This chart provides only a rough indication!
Achtung: Diese Tabelle dient nur zur ungefähren Bestimmung!

Measuring the stride length is another point of reference for identifying a suitable frame. Make sure that there is a minimum gap of one inch, so 2.54 cm, between your groin and the top tube („Fig. 1/ Gap in inches“ on page 24).

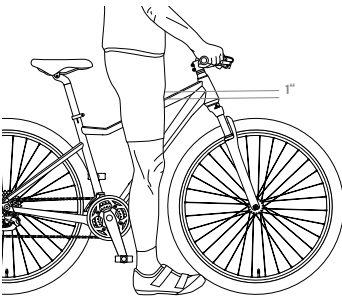

Fig. 1/24 Gap in inches

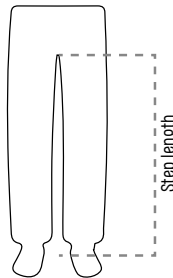

Fig. 2/24 Step length

Proceed as follows to measure your step length:

- Take off your shoes and stand with your back against the wall, your feet a shoulder's width apart
- Place a large book between your legs and against your groin, the spine of the book pointing upwards.
- Ask another person to measure the precise distance between the floor and the book's spine.

Seat height and saddle position



- If the diameter of the seat post is smaller than the seat tube, you can fit reduction sleeves with a minimum length of 70mm.
- Before every ride and after each adjustment, always check that the screw connections on the saddle are tight. Grip the front and rear of the saddle and move it to the left and right, i.e. up and down. On no accounts may you notice any displacement of the seat post.
- Do not undercut the minimum seat post insertion depth („Fig. 2/ Insertion depth“ on page 25). If necessary, select the next largest frame size.
- Avoid using force to insert the seat post into the seat tube.
- Expertise and special tools are always required for all adjustments, maintenance and care of your bicycle. Ask your KTM dealer to carry out all work.

The seat height is correctly adjusted when the heel of your foot is on the pedal axle and your leg is fully extended („Fig. 1/ Seat height“ on page 25). But your leg should be slightly bent when your heel is resting on the pedal axle.

- Ideally you should put on the cycling shoes you will use on your bike trips.
- Sit down properly on the saddle. Prop yourself up against a wall.
- Position your heel on the pedal axle in the lower position and make sure your hips are straight.
- Your leg should now be extended.



Fig. 1/25 Seat height

To adjust the seat height, flip the quick-release lever, i.e. the clamping bolt, on the seat tube – refer to “*Handling quick releases*” in the chapter on “*Wheels and tyres*” – and then adjust to the correct seat height. Now close the quick-release lever to mount the seat post. You will need the right tools if a clamping bolt was used to fix the seat post in place. Always use a torque spanner and adhere to the information on torques provided in the chapter on “*Recommended tightening torques*”. Turning the screw anticlockwise loosens it to adjust the seat post easily. Now turn the screw clockwise to fix the seat post in place.

Check that the saddle is in line with the top tube of the bicycle frame („Fig. 3/ Source Sram“ on page 25). If necessary, release the quick-release lever/clamping bolt on the seat tube and realign the saddle.

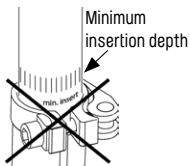

Fig. 2/25 Insertion depth

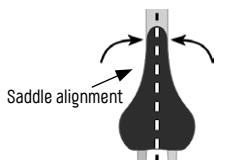

Fig. 3/25 Source Sram

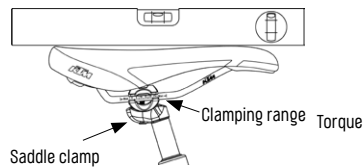

Fig. 4/25 Saddle assembly

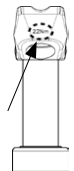

Fig. 5/25 Seat post

Each saddle must be mounted with the seat surface parallel to the ground („Fig. 4/ Saddle assembly“ on page 25). A spirit level is helpful during assembly. The allowed clamping range for the rails is marked on each saddle.

Most seat post manufacturers specify a torque for mounting the saddle which is noted directly on the seat post („Fig. 5/ Seat post“ on page 25) – refer to the chapter on “*Recommended tightening torques*”. If the seat post has two screws, the torques must each be checked twice alternately after tightening. The seat post must not be mounted the wrong way round, so the saddle clamp must be pointing backwards.

Handlebar height and stem settings



- The handlebars and stem are among the load-bearing components of your bicycle and hence are relevant to its safe operation. Expertise and special tools are always required for all adjustments, maintenance and care of your bicycle. Ask your KTM dealer to carry out all work.
- The selected handlebars-stem combination must be approved by their manufacturers.
- On no accounts should you ride a bicycle in which the minimum insertion depth of the stem has been undercut. The safety risk is too large.
- Check that the clamping bolts on the stem or handlebars are properly tightened by gripping the front wheel between your legs and attempting to twist the handlebar, stem and stem unit in all directions. Consult with your KTM dealer if you are able to twist the components.
- The connections between the stem and the steer tube, as well as between the stem and the handlebars, must be bolted correctly.
- If your stem is adjustable, check that it is firmly mounted before each trip.
- Check the brake functions before entering road traffic.

The seat height and the height of the handlebars determine the inclination of your back while riding the bicycle. Your seating position will become significantly more sporty if the handlebars are positioned lower. There are various stems that allow you to change the handlebar height. Your KTM dealer can advise you on the right seating position.



Particularly in cases where brake lines and gear cables are routed internally, take care not to twist the handlebars too far up or down, or to turn them too far to the left or right. This could damage the brake lines and gear cables located inside the stem/handlebar unit („Fig. 1/ Internally routed brake lines and shift cables“ on page 26).

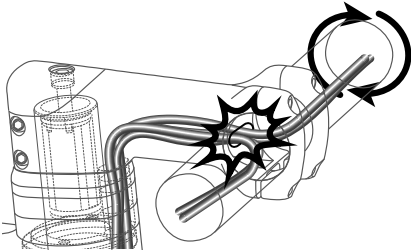

Fig. 1/26 Internally routed brake lines and shift cables

Conventional stems

The handlebar height on conventional stems („Fig. 2/ Stem tube“ on page 26) is adjusted by varying the insertion depth of the stem in the steer tube.

Adjustable stems

A tilting stem („Fig. 3/ Tilting stem“ on page 26) also allows you to adjust the position of the handlebars later on. To do this, the set angle is adjusted upwards or downwards. They are easy to retrofit and are available from your KTM dealer.

Threadless stem (Ahead)

The threadless stem („Fig. 4/ Ahead stem“ on page 26) is clamped directly onto the steer tube. The only way to adjust the height is to add spacers or rotate the stem. The handlebar height can only be reduced by cutting off a section of the tube. The handlebar height can be lowered or raised by turning the stem.



Fig. 2/26 Stem tube



Fig. 3/26 Tilting stem



Fig. 4/26 Ahead stem

Brake system:

General instructions



- Check the functionality and condition of the brakes before each ride.
- Never ride the bicycle without brake pads or with worn brake pads. Make sure that the pads are correctly fitted during inspections and when replacing them. In addition, always adhere to the safety and other instructions in the component guides issued by the individual brake system manufacturer.
- The brakes are among the safety components of your bicycle. Expertise and special tools are always required for all adjustments, maintenance and care of your bicycle. Ask your KTM dealer to carry out all work and check your bicycle according to the instructions provided in the chapter on *"Maintenance and Care Intervals"*.
- Only use original KTM parts if you replace any components.
- Regularly check hydraulic brake systems for leaks, i.e. check for leaking fluid along the brake line when the brake lever is pulled. Any leakage of brake fluid will impair the braking force. You should therefore never open the brake line.
- Your brake system may show a delayed response or cause the wheels to slip or the rear wheel to skid sideways on wet, slippery and loose surfaces. Test the effects of your brakes during wet weather and on loose surfaces and always apply the brakes carefully.
- Practice manoeuvres and check the brake system at a location without much traffic.
- Brakes can overheat if they are used continuously for a longer period. The braking force may be impaired or fail completely, i.e. the tube and tyres can be damaged if rim brakes are fitted. Apply the brakes carefully and intermittently to prevent this from happening.
- The brake disc and the brake calliper or the rim can become very hot during long braking manoeuvres – risk of burns!
- When factory new, disk brakes do not show the maximum braking force and require a running-in period of around 30–100 braking manoeuvres.
- Refer to the *"Bicycle registration document"* for information about the brake lever arrangement.
- All braking surfaces must be free of oil and grease.

Your bicycle must be brought to a stationary position as quickly as possible when you operate the brakes. If you brake suddenly, try to move your centre of gravity as far back as you can.

All KTM models are equipped with two brakes that function autonomously. In the factory fitting, the left-hand brake lever in the direction of travel operates the front brake, while the right-hand brake lever operates the back brake. As a UK customer your dealer should have changed this around for you to the UK set up. You should always press both brakes carefully and simultaneously when initiating a braking procedure. The greater braking force acts on the front wheel due to the shift in weight. Only one model-specific brake lever for the front brake can be fitted to a bicycle with coaster brake; it is then located on the right-hand side of the handlebars – refer to the chapter on the *"Bicycle registration document"*.

Grip widths of brake levers



- On no accounts should it be possible to pull the brake lever all the way into the handlebars before the brake pads touch the braking surfaces. It would otherwise be impossible to achieve the full braking power. Immediately consult with your KTM dealer in this case.

The distance between the brake lever and the handlebars can usually be adjusted. The brake lever can be moved to the most favourable position, depending on your height. When braking, the wrist should be in a straight line with the forearm. Your KTM dealer can advise you on the right adjustment for the grip width.

Mechanical rim brakes



- Pay attention to the condition of the rims. Tyre pressure may cause the rims to break if they are completely worn. The tube might burst or the wheel may become blocked.
- The brake cables must always be kept in a flawless condition. There must be no protruding wire strands, and the cables must be replaced when necessary.

The brake pad and rim close in this type of brake. Locking indicators in the form of grooves („Fig. 1/ Grooves“ on page 28) or dots („Fig. 2/ Dots“ on page 28) are applied directly to the rim flank. There may also be a wear indicator which, if it disappears completely, advises you to replace the rim. Wear on the brake pads is evident if the indicators disappear due to frequent braking. Also check wear of the rim when replacing the pads. If there is no visible indicator, check for cracks, unevenness or warping on the braking surfaces of the rim.

Rims made by *Ambrosio* are equipped with a 3-dot indicator. It consists of 3 holes on the rim flank of different depths. Besides showing when you need to replace a wheel, they also indicate the current wear status, depending on which holes remain visible. Replacing the wheel is recommended if only one hole is still visible.

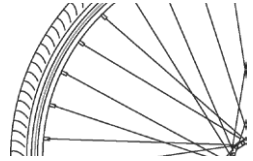

Fig. 1/28 Grooves

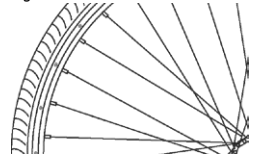

Fig. 2/28 Dots

V-brakes

V-brakes („Fig. 3/ Source Shimano“ on page 28) have one brake arm on each side of the rim. The brake cable pulls the brake arms on V-brakes inwards when the brakes are actuated. The brake pads fitted to the brake arms rub against the rim flanks and in doing so slow down the bicycle.

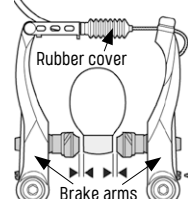

Fig. 3/28 Source Shimano

Checking the functions



- Make sure that the brake pads touch the rim flanks completely and on no accounts reach into the spokes or touch the tyre. This might otherwise block the wheel. Immediately consult with your KTM dealer if the settings are incorrect.
- A braking force limiter is not an ABS system. It merely delays blocking of the wheel.

The brake pads („Fig. 4/ Source Shimano“ on page 28) must have the necessary thickness. If the grooves on the pads have worn off, they must be replaced as a matter of urgency. When pulling the brake lever slowly, the pads on the right or left side should grasp the rim flanks in the front pad section at the same time. When the front pad section grasps the rim, the rear pad section should show a gap of 1 mm to the rim flank. This prevents squeaking sounds during braking manoeuvres. The pads must grip the rim flank completely if the brake lever is pulled tighter.

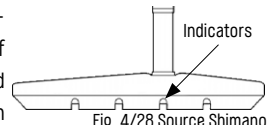

Fig. 4/28 Source Shimano

Braking force limiter

A braking force limiter can be used for some V-brakes („Fig. 5/ Source Shimano“ on page 28). It acts during each braking manoeuvre and limits the braking force by extending the cable travel within a certain brake lever force range.

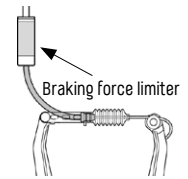

Fig. 5/28 Source Shimano

Side-pull brakes

Side-pull brakes are a closed loop system, as the brake arms share a common mounting mechanism („Fig. 1/ Source Shimano“ on page 29). Pulling the brake lever moves the brake pads inwards, where they rub against the rim flanks and cause the bicycle to slow down.



Fig. 1/29 Source Shimano

Checking the functions



- Make sure that the brake pads touch the rim flanks completely and on no accounts reach into the spokes or touch the tyre. This might otherwise block the wheel. Immediately consult with your KTM dealer if the settings are incorrect.
- All quick-release lever on the brakes must be closed when you are riding the bicycle.

The brake pads must have the necessary thickness. If the grooves on the pads have worn off, they must be replaced as a matter of urgency. The whole surface of the brake pads must grasp the right and left sides of the rim flanks at the same time. Side-pull brakes are equipped with a quick-release lever to remove the wheel from the fork or frame („Fig. 2/ Source Shimano“ on page 29). Opening this lever moves the brake pads outwards, and you can remove the wheel easily. The quick-release lever must always be closed while riding in order to effect the desired braking power. Some side-pull brakes have position markings to indicate that the brake is closed when the markings on the quick-release lever and on the brake housing are aligned („Fig. 3/ Source Shimano“ on page 29). The quick-release lever is quite inaccessible in some side-pull brake systems. In these cases, the quick-release lever is fitted directly to the shift cable („Fig. 4/ Source Shimano“ on page 29).

Fig. 2/29 Source Shimano

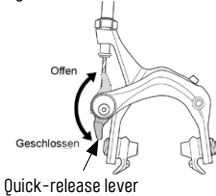

Fig. 3/29 Source Shimano

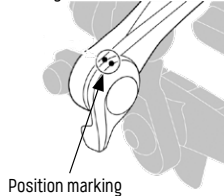
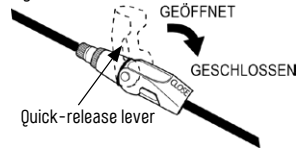

Fig. 4/29 Source Shimano



Hydraulic rim brakes

Many hydraulic rim brakes are more powerful than the mechanical variety. The brake shoes are pressed evenly against the rim flanks by means of brake fluid.

Checking the functions



- Make sure that the brake pads touch the rim flanks completely and on no accounts reach into the spokes or touch the tyre. This might otherwise block the wheel. Immediately consult with your KTM dealer if the settings are incorrect.

The wear indicator on the brake pad („Fig. 5/ Source Magura“ on page 29) shows the degree of wear. The pads must be replaced if the grooves have worn off completely. When pulling the brake lever slowly, the pads on the right or left side should grasp the rim flanks in the front pad section at the same time. When the front pad section grasps the rim, the rear pad section should show a gap of 1 mm to the rim flank. This prevents squeaking sounds during braking manoeuvres. The pads must grip the rim flank completely if the brake lever is pulled tighter.

Fig. 5/29 Source Magura

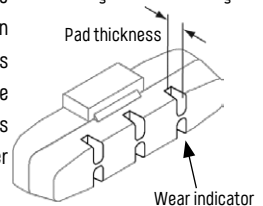

Disk brakes

The benefits of disk brakes („Fig. 1/ Source Sram“ on page 30) are their excellent braking performance, as well as their very good tolerance of dirt and weather influences. The brakes respond well even in wet weather, although they do tend to make noises.



Fig. 1/30 Source Sram

Checking the functions



- The brake disc must be replaced as soon as its thickness falls below the respective wear limit. Pay attention to engravings or markings on the brake disc indicating the wear limit and also observe the safety instructions and instructions in the component manual issued by the individual brake manufacturer.
- Expertise and special tools are always required to make adjustments to the brake or to perform maintenance and care. Ask your KTM dealer to carry out all work and check your bicycle according to the instructions provided in the chapter on “Maintenance and Care Intervals”.
- If your brake system works with DOT brake fluid, it must be replaced regularly according to the manufacturer’s instructions – special expertise is required.
- Make sure that the brake disc is not damaged during transport and use the transport protection when removing the front wheel.

Some disk brake models have a window on the brake calliper that shows the distance between brake pad and brake disc. The brake disc must be true and run smoothly between the pads. A decline in braking power may indicate wear on the brake pads. You should therefore remove the brake pads regularly to check them for wear.

The following diagrams („Fig. 2/ Source Shimano“ on page 30, „Fig. 3/ Source Shimano“ on page 30) show the most common arrangements of brake pads and how they are dismantled.

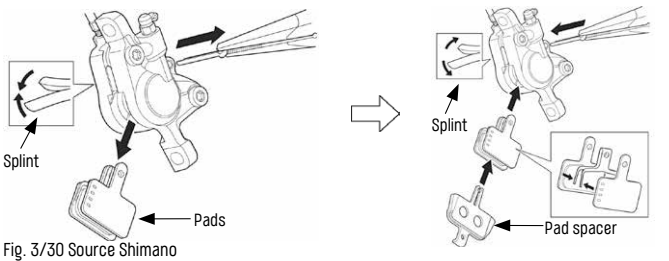
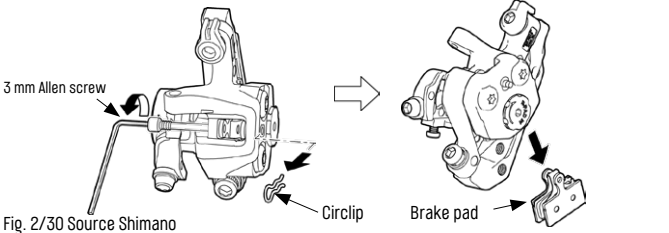

In general, the brake pads should be replaced if

- they have reached the applicable wear limit – refer to „Fig. 1/ Source Tektro“ on page 31
- there is uneven wear on the surface
- they are contaminated with oil
- the retainer/return spring rubs against the brake disc

The thickness of the brake pad and the mounting bracket (refer to „Fig. 1/ Source Tektro“ on page 31) are measured to determine the pad thickness. The pads must be replaced if the measured value is lower than the value in the column “Brake pads + mounting bracket” in the following table.

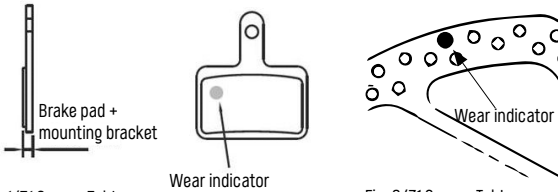

Fig. 1/31 Source Tektro

Wear indicator

Fig. 2/31 Source Tektro

The brake discs must also be replaced as soon as their thickness falls below the relevant wear limit. In some cases, there are indicators directly on the brake disc so that you can check the wear („Fig. 2/ Source Tektro“ on page 31). They may be coloured indentations on the brake disc. The brake disc must be replaced as a matter of urgency if the colour has worn off completely and the indentation has disappeared. Reduced braking performance and a noticeable scratching sound during braking manoeuvres may also indicate excessive wear.

Manufacturer	Brake pad wear limit	Brake pad + mounting bracket	Brake disc wear limit
Shimano	0.5 mm	2.5 mm	1.5 mm
Tektro	0.5 mm	2.5 mm	1.9 mm
Magura	0.5 mm	2.5 mm	1.8 mm

Coaster brakes

These brakes are activated by rotating the crank backwards relative to the direction of travel. The performance of the coaster brakes will be highest when the cranks are in a horizontal position.

Checking the functions



- Coaster brakes are fitted with a centre bolt („Fig. 3/ Centre bolt; source Shimano“ on page 31), which rests on the chain stay of the frame. For correct operation, it must be firmly mounted using a fastening clip or directly on the chain stay.
- The coaster brake cannot be operated effectively if the chain has slipped off or the chain tension is insufficient.
- Immediately consult with your KTM dealer if the settings are incorrect.

Regularly press the chain up and down to check the chain tension as well („Fig. 4/ Chain tension“ on page 31). It must not be possible to push or pull the chain up or down by more than 2 cm between the two sprockets.

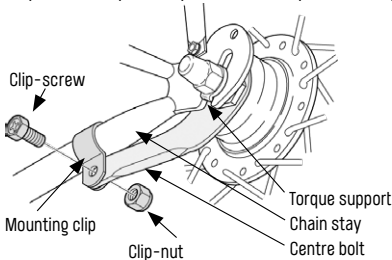

Fig. 3/31 Centre bolt; source Shimano

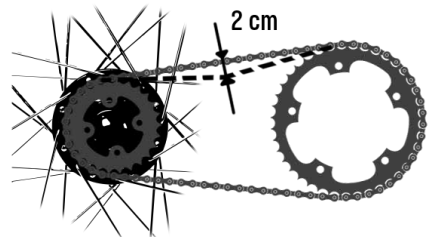

Fig. 4/31 Chain tension

Propulsion

General instructions



- Expertise and special tools are always required for all adjustments, maintenance and care of your propulsion system. Ask your KTM dealer to carry out all work and check your bicycle according to the instructions provided in the chapter on *"Maintenance and Care Intervals"*.
- Always adhere to the safety and other instructions in the component guides issued by the individual shift system manufacturer.
- Practice shifting and check the shifting system at a location without much traffic.
- Never shift gears when pedalling backwards, as the shifting system may otherwise block. Never shift gears when the bicycle is stationary, as this might otherwise damage the components.
- Pedal evenly and with low force during the shifting process to prevent the chain from slipping.
- The propulsion system must be configured very precisely. Incorrect adjustment may cause the chain to jump off, leading to an abrupt interruption of propulsion.
- Wear clothing suitable for cycling that does not catch in the rotating parts of the propulsion system when pedalling.

The drive system transmits the force from crank rotation and consists of the following components: Pedals, crank arms, bottom bracket, chainring, chain and cassette.

The purpose of the shifting system is to adjust the force that must be exerted on the pedals to suit the terrain characteristics and speed of travel. Steep ascents can be managed with little exertion by selecting a low gear requiring a high pedalling frequency. A high gear is used to travel a longer distance at higher speed per crank rotation, for instance when travelling downhill.

Cyclists experience the greatest health benefits, build up the most endurance and achieve the best performance by rotating the cranks at a relatively high cadence (approx. 60-90 rpm) with little effort.

Use the entire range of gears to find the ideal rhythm in the different riding conditions. Moving parts of the shifting system should be cleaned and treated with a suitable lubricant immediately after a ride in wet weather.

Bottom bracket and chainset



- Clearance between the crank and the spindle may cause the crank set to break.

Most bottom brackets are compact bearing units comprising ball bearings, bearing cups, sealing rings and the axle. The sealed construction prevents the penetration of moisture and dirt.

A variety of model-specific bottom brackets can be used, which are delivered with all factory settings already made. The bottom bracket and crank arms may loosen with time. Check regularly that the inner bearings are firmly mounted in the bottom bracket shell and that the crank arms are firmly attached to the axle by pushing the left crank arm towards the chain stay. There must neither be clearance nor clicking or scraping sounds.

Derailleur gears

Derailleur gears work as follows:

- | | | | | |
|------------------------------|---|------------|---|---------------------|
| Small chainring at the front | → | small gear | → | lower transmission |
| Large chainring at the front | → | big gear | → | higher transmission |
| Small sprocket at the back | → | big gear | → | higher transmission |
| Large sprocket at the front | → | small gear | → | lower transmission |



Fig. 1/33 Positive example for the chain position



Fig. 2/33 Negative example for the chain position

Make sure that the chain is not running at a slant (large chainring at the front to the large sprocket at the back – refer to „Fig. 2/ Negative example for the chain position“ on page 33 – or small chainring at the front to small sprocket at the back) as the components will otherwise experience greater wear and the efficiency of the propulsion system will be impaired. As a rule, the shift levers to move the chain on the chainrings or the sprocket are attached to the handlebars as follows:

- | | | |
|----------------------------|---|---|
| Left-hand gear lever unit | → | derailleur switches the chain on the front chainring |
| Right-hand gear lever unit | → | rear derailleur switches the chain on the rear sprocket |

Derailleur gears by the manufacturers Shimano (Di2) and Sram (AXS) are available in both mechanical and electronic versions. Please note that a battery or rechargeable battery is required to operate the electronic shift lever/rear derailleur. The power on some models is supplied to the rear derailleur directly via the EPAC's main battery. Contact your KTM dealer if you are uncertain.

Operating mountain, trekking, city and children's bikes

In general, a shifting process is always initiated when a lever on the gear lever unit or the brake-shifting unit is operated, depending on the shifting system used. Grip shifters are operated by a short twist of the wrist.

Shimano Rapidfire Plus

The gear lever unit located on the left-hand side of the handlebars from the rider's perspective operates the derailleur („Fig. 3/ Gear lever unit, derailleur“ on page 33), which positions the chain on the front chainrings. The rider presses the protruding 1-finger lever to move the chain from the large to the small chainrings. The opposite process is initiated by pressing the thumb lever, and the chain moves from the smaller chainrings to the larger chainrings. The gear lever unit located on the right-hand side of the handlebars from the rider's perspective operates the rear derailleur („Fig. 4/ Gear lever unit, rear derailleur“ on page 33), which positions the chain on the rear sprocket. The rider presses the front 1-finger lever to move the chain towards the small sprocket. The opposite process is initiated by pressing the thumb lever, and the chain moves from the smaller sprockets to the larger sprockets.

Some Shimano Rapidfire Plus shift lever are fitted with an additional 2-way release. This shift lever maintains the same shifting logic described above, but the 1-finger lever can also be operated using the thumb. The technology also allows riders to skip through several gears with just one lever movement. Briefly tapping the right-hand thumb lever shifts to the next gear. Depressing the right-hand thumb lever enables the rider to move through several gears at once. The shifting logic is precisely the other way round for Shimano Rapid Rise shift levers.

Fig. 4/33 Gear lever unit, rear derailleur
Source Shimano

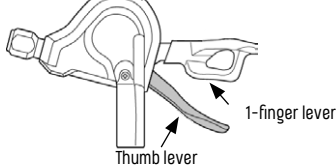
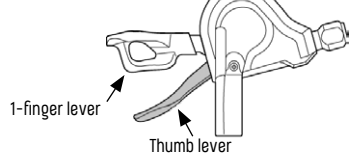
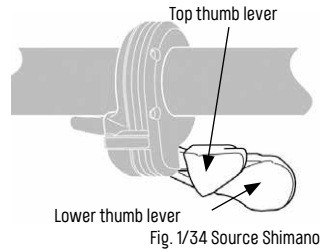

Fig. 3/33 Gear lever unit, derailleur
Source Shimano



Shimano Di2 / TRP E.A.S.I

In the basic configuration selected by KTM, the gear lever unit located on the right-hand side of the handlebars from the rider's perspective operates the rear derailleur („Fig. 1/ Source Shimano“ on page 34), which positions the chain on the rear sprocket. The rider presses the upper thumb lever to move the chain towards the small sprocket. The opposite process is initiated by pressing the lower thumb lever, and the chain moves from the smaller sprockets to the larger sprockets. Each lever on the Shimano gear lever unit can also skip through several gears at once if the buttons are pushed further forward in each shifting process.



The TRP E.A.S.I can shift through several gears if you press and hold the shift lever. A separate button on the TRP shift lever lets you switch between manual and automatic shift mode.

The electronic Shimano Di2 shifting system has freely configurable software. The "e-tube project" software can be downloaded free of charge from the Shimano website. The Shimano SM-PCE1 connection device is also required as an interface between the PC and the bicycle components (not included). All settings can be made on the electronic shifting system once the bicycle components have been connected with the software.

Sram Trigger

The gear lever unit located on the right-hand side of the handlebars from the rider's perspective operates the rear derailleur („Fig. 2/ Trigger; source Sram" on page 34), which positions the chain on the rear sprocket. The rider presses the front 1-finger lever to move the chain towards the small sprocket. The opposite process is initiated by pressing the thumb lever, and the chain moves from the smaller sprockets to the larger sprockets.



Sram Eagle AXS

In the basic configuration, the shift paddle located on the right-hand side of the handlebars from the rider's perspective operates the rear derailleur, which positions the chain on the rear sprocket.

The rider presses the shift paddle downwards (refer to Fig. 1 "Fig. 3/ Source Sram" on page 34) to move the chain towards the small sprocket.

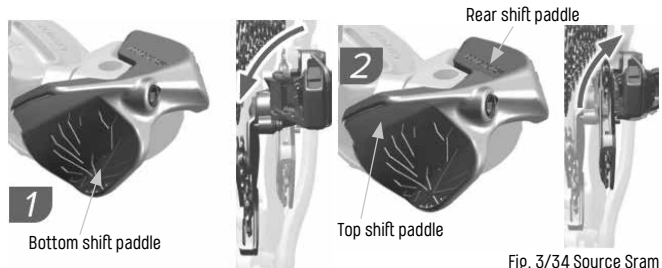

The opposite process is initiated by pressing the shift paddle downwards or by pressing the rear part of the shift paddle (refer to Fig. 2 „Fig. 3/ Source Sram" on page 34), and the chain moves from the smaller sprockets to the larger sprockets.

The electronic shift paddle is connected to the rear derailleur by wireless technology. It needs a battery and is freely configurable using an app. The Sram AXS app can be downloaded free of charge from the app stores.

Operating the shifting system on racing bikes

Shimano Dual Control

The shift-brake arm unit located on the left-hand side of the handlebars from the rider's perspective operates the derailleur („Fig. 1/ Source Shimano“ on page 35), which positions the chain on the front chainrings. The rider presses the left-hand shift lever to move the chain from the large to the small chainrings. The opposite process is initiated by moving the left-hand brake lever sideways, and the chain moves from the smaller chainrings to the larger chainrings.

The shift arm unit located on the right-hand side of the handlebars from the rider's perspective operates the rear derailleur („Fig. 1/ Source Shimano“ on page 35)

and positions the chain on the rear sprocket. The rider presses the right-hand shift lever to move the chain towards the small sprocket. The opposite process is initiated by moving the right-hand brake lever sideways, and the chain moves from the smaller sprockets to the larger sprockets. The right-hand brake lever can also skip through several gears at once if the lever is pushed further inwards.

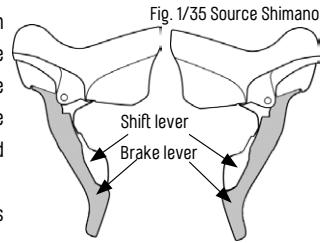

Shimano Di2

The shift-brake arm unit located on the left-hand side of the handlebars from the rider's perspective operates the derailleur („Fig. 2/ Source Shimano“ on page 35), which positions the chain on the front chainrings.

The rider taps the left-hand, rear shift lever to move the chain from the large to the small chainrings. The opposite process is initiated by tapping the left-hand, front shift lever, and the chain moves from the smaller chainrings to the larger chainrings. The shift arm unit located on the right-hand side of the handlebars

from the rider's perspective operates the rear derailleur („Fig. 2/ Source Shimano“ on page 35) and positions the chain on the rear sprocket. The rider taps the right-hand, rear shift lever to move the chain towards the small sprocket. The opposite process is initiated by tapping the right-hand, front shift lever, and the chain moves from the smaller sprockets to the larger sprockets. The electronic shifting system has freely configurable software. The "e-tube project" software can be downloaded free of charge from the Shimano website. The Shimano SM-PCe1 connection device is also required as an interface between the PC and the bicycle components (not included). All settings can be made on the electronic shifting system once the bicycle components have been connected with the software.

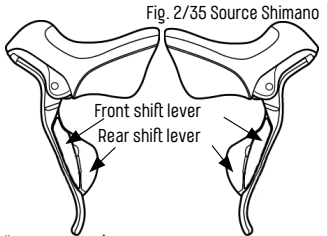

SRAM Double Tap

The shift arm located on the left-hand side of the handlebars from the rider's perspective operates the derailleur, which positions the chain on the front chainrings. If the shift lever is moved slightly sideways, the chain moves from the large to the small chainrings. The opposite process is initiated if the shift lever is moved further inwards, and the chain moves from the smaller chainrings to the larger chainrings.

The shift arm unit located on the right-hand side of the handlebars from the rider's perspective operates the rear derailleur and positions the chain on the rear sprocket. If the shift lever is moved slightly sideways, the chain moves towards the small sprocket. The opposite process is initiated if the shift lever is moved further inwards, and the chain moves from the smaller sprockets to the larger sprockets.

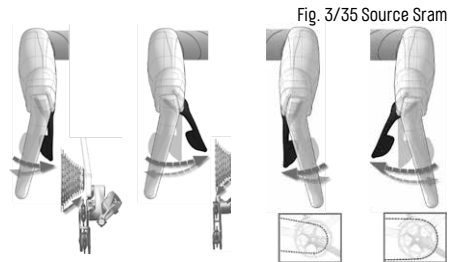

SRAM eTap AXS

The rear derailleur is moved inwards by tapping the left-hand shift lever. The chain moves to the next larger



Fig. 1/36 Source Sram

sprocket. Press and hold the shift lever to skip through several gears. The rear derailleur is moved outwards by tapping the right-hand shift lever. The chain moves to the next smaller sprocket. If the left and right-hand shift lever are pressed at the same time, the chain moves across the derailleur to the small, i.e., large, chainring at the front.

The electronic switch-brake lever unit is connected to the rear derailleur by wireless technology. It needs a battery and is freely configurable using an app. The Sram AXS app can be downloaded free of charge from the app stores.

Hub gears

Hub gears are operated using a planetary gear, either by twisting a grip shifter or pressing a thumb shift lever. A distinction is made between freewheel and coaster hubs. In coaster hubs, a fitted drum brake is activated by back pedalling the cranks. The braking effect is greatest when the crank arms are in a horizontal position. A bicycle chain or a belt can be used for propulsion.

Operating hub gears

Riders should pedal with only a little force or not at all during the shifting process. The grip shifter („Fig. 2/ Source Shimano“ on page 36) or thumb shift lever („Fig. 3/ Source Shimano“ on page 36) is fitted on the right of the handlebars.

There is a gear display to indicate the currently active gear. Turning the grip shifter

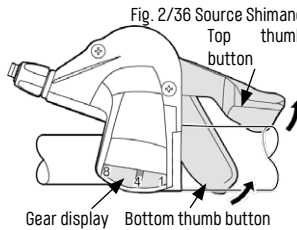

Fig. 2/36 Source Shimano

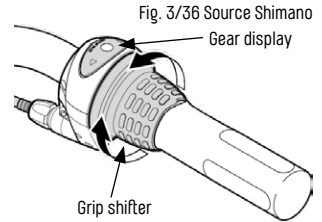

Fig. 3/36 Source Shimano

clockwise or pressing the thumb button at the bottom moves to a lower transmission. Turning the grip shifter anticlockwise or pressing the thumb button at the top moves to a higher transmission.

The grip shifter in the manual envio group works according to the same shifting principles. Transmission between the pedal and the rear wheel is infinitely adjusted in this system and therefore changes in a continuous flow. The current transmission range is shown on the display when riding the bicycle.

- Clockwise rotation: Display shows a "Uphill" („Fig. 4/ Source Enviolo“ on page 36). This transmission should be selected to start or to ride uphill.
- Anticlockwise rotation: Display shows "level terrain" („Fig. 5/ Source Enviolo“ on page 36). This transmission should be selected for faster travel.

The Enviolo shifting group is compatible with belt drives - refer to the section on "Belts".

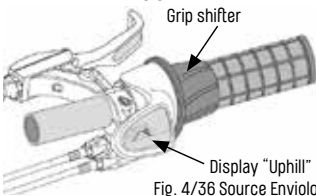

Fig. 4/36 Source Enviolo

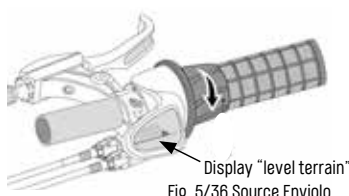

Fig. 5/36 Source Enviolo

Chain

Chain wear and care



- Shifting processes during phases of high load may damage or even break the chain.
- Lubricant must not penetrate the braking surfaces on the rim, the brake pads or the brake discs. This would reduce or, in the worst case scenario, eliminate the braking force.
- Only replace the chain with a suitable and comparable chain type with the same width and length. The number of chain links must be identical to the number in the original chain.
- Check the chain regularly for damage such as deformations and cracks. Unintentional gear shifting or skipping of a sprocket are indicative of a defective chain.
- Expertise and special tools are always required for all adjustments, maintenance and care of your propulsion system. Ask your KTM dealer to carry out all work and check your bicycle according to the instructions provided in the chapter on "Maintenance and Care Intervals".

Maintenance is important to ensure the durability and quiet operation of the chain. Adhere at all times to the instructions provided in the chapters on "Maintenance and care instructions" and "Maintenance and care intervals".

Maintenance intervals depend partly on the riding conditions. The chain is exposed to greater environmental wear in the winter months especially. Apply a suitable lubricant to the chain, especially during wet weather.

The chain should be cleaned regularly using a neutral detergent. On no accounts should you use alkali or acidic solvents such as rust removers. Then apply chain oil or grease to the chain's inner rollers. Press the crank to rotate the chain several times. Now leave the bicycle for a few minutes so that the lubricant can penetrate the chain.

When shifting gears, pedal with reduced force and avoid selecting a gear in which the chain runs at an angle. Always pedal at a high cadence so that the chain is not exposed to unnecessarily high strain.

Refer to the chapter on "Maintenance and care intervals" for information about wear limits. The shifting process will deteriorate significantly if the chain has become elongated due to wear. The sprockets and chainrings will also wear out if the chain is not replaced in good time. Compared to the chain, replacing these components would cost considerably more.

Make sure that the chain is correctly tensioned at all times. On bicycles equipped with hub gears, the chain is properly tensioned if it can be moved up and down by 1 to 2 cm between the chainring and the sprocket.

You can use a wear gauge to determine the wear on your chain. The recess of the wear gauge is attached to a roller and moved back and forth on the chain with the probe pointing downwards. In a new chain, the probe tip just about fits between the rollers (.,Fig. 1/ Low wear" on page 37). The probe can penetrate deeper into the rollers if wear is more severe. The chain should be replaced in order to avoid wear on other components if the measuring side is completely inserted so that the gauge rests on the rollers along the entire measured length (.,Fig. 2/ High wear" on page 37).

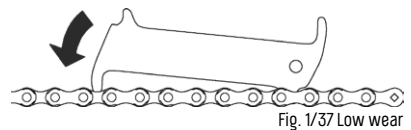

Fig. 1/37 Low wear

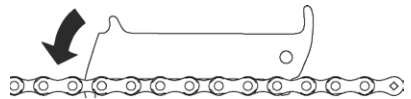

Fig. 2/37 High wear

Belts

A toothed carbon fibre belt is a low-maintenance alternative to a conventional bicycle chain. In principle, a distinction must be made between the more robust CDX system (EPAC) and the CDN system (bicycle), each of which has a central track („Fig. 1/ Source Gates“ on page 38).

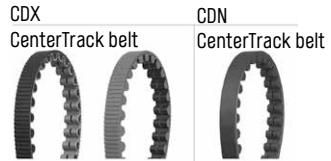

Fig. 1/38 Source Gates

Belt wear and care



- Keep parts of your body and clothing away from the propulsion system while it is moving.
- Do not fold, twist, bend backwards or turn over the belt and do not tie it in knots or together. Never use the belt as a strap spanner or chain whip. Never roll up the belt with the sprocket or lever it into place („Fig. 2/ Source Gates“ on page 38)
- Check the belt at regular intervals for damage such as cracks, missing teeth or exposed carbon fibres („Fig. 3/ Belt wear; source Gates“ on page 38)
- Only replace the belt with a suitable and comparable belt type with the same width and length.
- Do not lubricate the belt.
- Expertise and special tools are always required for all adjustments, maintenance and care of your propulsion system. Ask your KTM dealer to carry out all work and check your bicycle according to the instructions provided in the chapter on “*Maintenance and Care Intervals*”.

A certain degree of care is essential to reduce belt wear. Observe the following points:

- Only use water to remove dirt.
- Temperature limits for CDN belts (bicycles): -20 °C to 60 °C
- Temperature limits for CDX belts (EPAC): -53 °C to 85 °C

Do not roll up with the sprocket Do not lever into place



Fig. 2/38 Source Gates

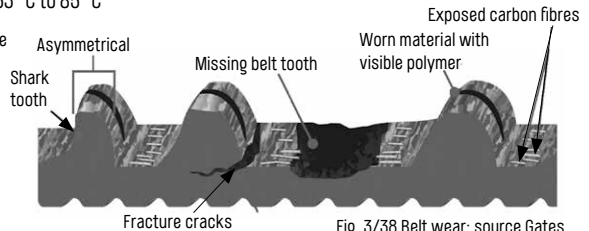

Fig. 3/38 Belt wear; source Gates

The carbon belt must always be tensioned correctly to ensure that the carbon drive system works properly. For instance, the belt tension may be too if the belt teeth slip over the teeth of the rear sprocket. Excessive belt tension will make the system noticeably more laborious to operate.

Checking the functions

Check that your propulsion system is working properly. If necessary, ask another person for help by lifting the tail of the bicycle while you rotate the crank. Contact your KTM dealer if you notice any of the following irregularities:

- Chain tension must be adequate. The chain must not fall off the front chainring or the rear sprocket.
- The gear does not change, or does not change correctly, during the shifting process.
- Propulsion components must not block under any circumstances.
- On no accounts should there be noticeable noises such as loud grinding, clicking, banging or crunching during pedaling, neither should there be any irregular resistance.

Wheels and tyres:

General instructions



- Expertise and special tools are always required to make adjustments to the wheels and tyres or to perform maintenance and care. Ask your KTM dealer to carry out all work and check your bicycle according to the instructions provided in the chapter on "Maintenance and Care Intervals".
- Always adhere to the safety and other instructions in the component guides issued by the wheel and tyre manufacturer.
- The wheel is exposed to severe stress due to the weight of the rider and the bicycle, as well as uneven terrain. Spokes and nipples subside on a new bicycle, so the wheel will need servicing by your KTM dealer.
- Incorrectly mounted wheels and thru axles are a significant safety risk. Adhere to the torque details provided in the chapter on "Recommended tightening torques" and use a suitable torque spanner.

The hubs on wheels are connected to the rim by spokes and nipples. The tyre is usually mounted on the rim with a tube. Rim tape is applied additionally between the tyre, tube and rim in order to prevent damage.

Handling thru axles

Thru axles connect the wheel to the fork, i.e. the frame, of the bicycle. There are many different thru axle systems available on the market at present. Special tools are needed for some systems.

To fit the wheel, place it in the intended mountings on the fork. Introduce the brake disc into the brake calliper. Then proceed with the instructions for the specific system on the following pages.

Maxle thru-axle system

This system is used in connection with Rock Shox suspension forks. The thru axle is inserted through the fork and hub of the wheel from the right, viewed in the direction of travel. As soon as the thru axle touches the thread on the left fork leg, it can be screwed to the fork. Position the quick-release lever in the axle recess and turn it anticlockwise to fix the wheel in place (.,Fig. 1/ Maxle Source Sram" on page 39).

Then close the quick-release lever by pushing it inward with the ball of your thumb. You should encounter virtually no resistance for around half the lever travel; the lever force should then increase considerably from then, and it should be difficult to close towards the end. If it is too easy to press the quick-release lever inwards, open it, replace it in the axle recess and turn the quick release a little further in a clockwise direction. If the opposite is the case and the quick-release lever is too hard to close, open it again and loosen the quick release slightly by turning it an anticlockwise direction. Make sure that the quick-release lever can be closed as described above.

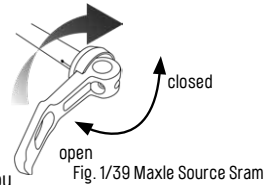

E-Thru thru-axle system

The E-Thru thru axle system is used together with Fox suspension forks. The thru axle is inserted through the fork and hub of the wheel from the left, viewed in the direction of travel (.,Fig. 2/ E-Thru Source Shimano" on page 39). As soon as the thru axle touches the thread on the right fork leg, it can be screwed to the fork. Then close the quick-release lever by pushing it inward with the ball of your thumb.

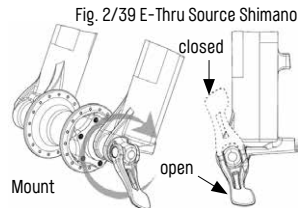

You should encounter virtually no resistance for around half the lever travel; the lever force should then increase considerably from then, and it should be difficult to close towards the end. If it is too easy to press the quick-release lever inwards, open it, replace it in the axle recess and turn the quick release a little further in a clockwise direction. Then try to close the quick-release lever again by pushing it inward with the ball of your thumb. If it is too hard to press the quick-release lever inwards, open it, replace it in the axle recess and turn the quick release a little further in an anticlockwise direction. Then try to close the quick-release lever again by pushing it inward with the ball of your thumb.

Q-Loc thru-axle system

This thru-axle system is used together with Suntour suspension forks. The wheel is mounted using a quick-release lever and a flange on the opposite side, which provides the necessary clamping force (.,Fig. 1/ Source Suntour“ on page 40). The thru axle is inserted through the fork and hub from the right, viewed in the direction of travel. Complete this step with the quick-release lever fully open so that the thru axle flange fits through the fork dropouts. Adjust the tension of the quick-release lever by turning the flange.

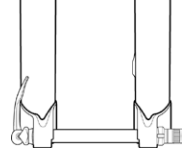

Fig. 1/40 Source Suntour

Turn the flange in a clockwise direction until it touches the fork drop out with the quick-release lever half open. Then use the ball of your thumb to close the quick-release lever hand-tight. You may have to re-tighten the system after checking that the quick release and the wheel are correctly positioned.

KTM thru-axle systems

This thru-axle system is mainly used to mount the rear wheel. This thru-axle system may also be used on the fork, depending on the specific model. In this case, the thru axle is always through the drop out in the frame or on the fork from the left, viewed in the direction of travel. The thru axle is fixed in place by clockwise rotation. Tighten the lever as hard as you can by hand (10 Nm).

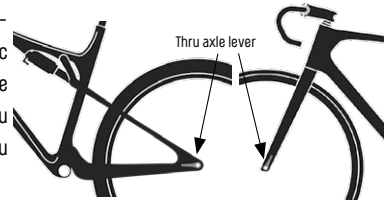

Fig. 2/40 KTM thru axle

If the lever is not parallel to the chain stay,

i.e. the fork leg (.,Fig. 2/ KTM thru axle“ on page 40), you can change the position of the thru axle lever afterwards. To do this, loosen the 4 mm Allen screw and then move the lever to the desired position. Tighten the 4 mm Allen screw with 5 Nm torque.

Handling quick releases

Quick releases are used to enable rapid assembly and removal of wheels or to adjust the height of the saddle. A quick release essentially consists of a hand lever to provide the clamping force and an adjusting nut on the opposite side, which alters the preload on the quick release. The hand lever must be open when placing the hub in the mountings. The hub should also be flush with the inside of the mountings (.,Fig. 3/ Source Shimano“ on page 40).

You need to apply quite a lot of force to close the hand lever to ensure that it does not open unintentionally while you are riding the bicycle. The adjusting nut needs to be tightened slightly if the lever is too easy to close. It should then take a little more force to close the hand lever (.,Fig. 4/ Source Shimano“ on page 40). Repeat the process if the resistance during closing is still insufficient.

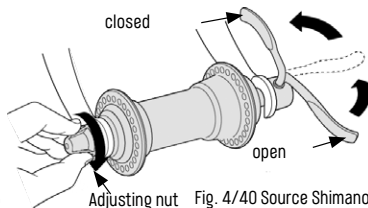
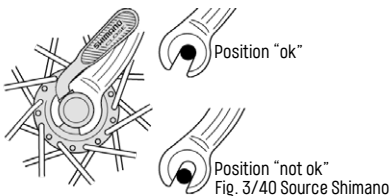

Information on the rim

The maximum permissible air pressure and the minimum and maximum possible tyre widths are indicated on the rim flanks („Fig. 1/ Representative image, rim sticker“ on page 42). The inner rim width determines the maximum possible tyre dimension („Fig. 2/ Source Schwalbe“ on page 42). In addition, the tyre diameter must match the bead seat diameter. For instance, a tyre size of 37–622 will fit onto a rim measuring 622 x 19C, as the inner diameter of the tyre corresponds to the bead seat diameter of 622 mm.

Fig. 1/42 Representative image, rim sticker

poss. Tyre width in mm Maximum permissible air pressure/tube types

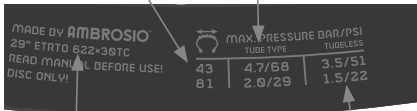

Rim dimensions

Maximum permissible air pressure/tubeless

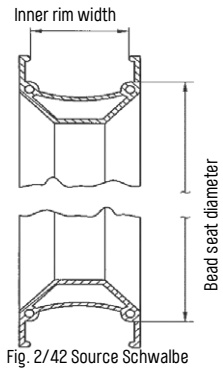

Rim models

It is important to pay attention to which type of rim is used. A basic distinction is made between a "hook-bead rim", in which the rim flanges close inward at the top with a hook, and hookless rims, which are frequently used in sports („Fig. 3/ Representative image, rim types“ on page 42). Hookless rims do not automatically grip and true the tyre and also have a very smooth surface, so particular care is required when mounting this type of rim.

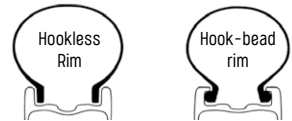

Fig. 3/42 Representative image, rim types

Tubeless

Certain tyre systems are designed as tubeless versions in connection with particular wheel systems. Simply ask your KTM dealer and pay attention to the tubeless information on the rim flanks („Fig. 1/ Representative image, rim sticker“ on page 42).

Valve models

A valve is needed to pump up the tyre. The following three valve types are used:

1. Dunlop valve („Fig. 4/ Source Schwalbe“ on page 42)
2. Presta valve („Fig. 5/ Source Schwalbe“ on page 42)
3. Car valve („Fig. 6/ Source Schwalbe“ on page 42)

A plastic cap is placed on all valve types to protect them from dirt.



Fig. 4/42 Source Schwalbe



Fig. 5/42 Source Schwalbe



Fig. 6/42 Source Schwalbe

The Presta valve is a common type. The upper lock nut must be loosened before pumping up the tyre. You can tape on the top to check whether it is ready – if air is emitted from the tube, the valve is ready for the pump. The slender pin held in place by the lock nut must not bend when applying and removing the pump. Once pumping is complete, the lock nut must be tightened again to prevent air from escaping.

Spoke tension and rim trueness



- Wheels that are not properly true make it difficult to know how strongly you should apply the brakes. This is because the brake pads engage with the brake surfaces on the rim with unusual strength due to the squint alignment.
- Loose spokes on your wheels must be re-tensioned as soon as you notice them. The stress exerted on other components rises considerably if you do not. Component breakage or failure may cause accidents or falls that lead to injuries.

Spokes must have equal tension so that the wheel can turn smoothly and truly. One or several spokes may become detached due to external influences.

The brake pads on rim brakes act on the braking surfaces on the side of the rim. Brake efficiency may be negatively impacted if the wheel is not true.

It is important to check rim trueness on a regular basis. Pay attention to the gap between rim and brake pads, i.e. frame or fork, when the wheel is turning. It should be even. Your KTM dealer must urgently check and service the wheel if the gap varies by more than a millimetre.

Punctures

Punctures are one of the most frequent causes of breakdowns when cycling. They can be fixed if you carry the right tools, a spare tube or a repair kit.

Dealing with punctures



- The brake disc or rim flank can become very hot during braking. Allow the components to cool down before starting to remove the wheel.
- Incorrectly fitted tyres may impair functions or damage the tyres. You must therefore proceed according to the instructions provided in this document, and ask your KTM dealer if you are uncertain.

To fix the puncture, remove the wheel by opening the thru axle, the quick-release lever or the hub axle nut – refer to the section on “*Handling thru axles*” and “*Handling quick releases*”. The procedure for removing the wheel differs for each brake type and shifting system. Also adhere to the following instructions for removing the wheel before you start repairing the puncture.

Removing the wheel for side-pull brakes

To remove the wheel from the fork or frame, you must open the quick-release lever on the brake or shift cable – refer to the section on “*Side-pull brakes*” in the chapter on the “*Brake system*”.

Removing the wheel for disk brakes

On no accounts should you press the brake lever on the disk brakes after removing the wheel. After removing the wheel, attach the supplied transport lock to the brake to prevent the pistons on the brake calliper from moving too far inwards and causing problems when refitting the wheel – refer to the section on “*Disk brakes*” in the chapter on the “*Brake system*”.

Removing the wheel for V-brakes

Press both brake arms together to release some tension from the brake cable. Push the rubber cover to one side and unhook the brake cable at this point – refer to the section on “*V-brakes*” in the chapter on the “*Brake system*”.

Removing the wheel for hydraulic rim brakes

When removing wheels fitted with hydraulic rim brakes made by Magura, the quick-release lever on one side of the brakes must be opened by turning it downwards („Fig. 1/ Source Magura“ on page 44). Then remove the entire brake cylinder from the retainer - refer to the section on “Hydraulic rim brakes” in the chapter on the “Brake system”.

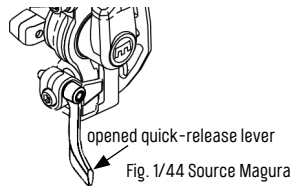

Removing the wheel for hub gears

Select the lowest gear to remove rear wheels with hub gears - refer to the section on “Hub gears” in the chapter on “Propulsion”. This relieves the tension on the shift cable. If the hub gear has a coaster pedal function, the screw connection on the centre bolt connected to the left chain stay must be loosened. Then pull the cable housing out of the cable housing holder and remove the shift cable through the slit on the inside of the cable housing holder. The mounting screw on the shift cable must then be released from the shifting unit („Fig. 2/ Source Shimano“ on page 44).

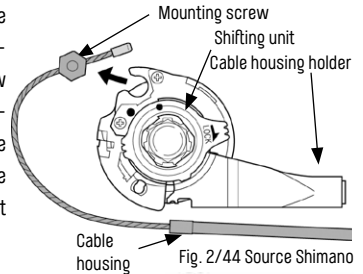

Enviolo hubs should be shifted to a position in which the locking lever and cable end stops are easily accessible. („Fig. 3/ Source Enviolo“ on page 44). Once the locking lever has been opened (A), the two cable end stops (B) and (C) can be removed.

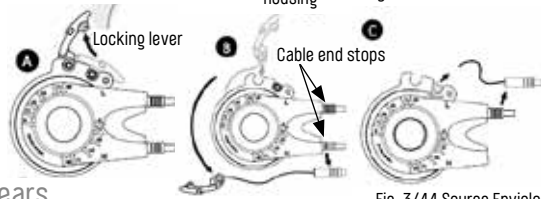

Removing the wheel for derailleur gears

Move the chain to the smallest sprocket on the rear sprocket to remove the rear wheel. The rear derailleur will then be in its outermost position and will not interfere while you remove the wheel. Move the small lever on the rear derailleur to the OFF position to facilitate wheel removal. Only then open the thru axle or quick release. To release the wheel from the mountings on the frame, lift the bicycle slightly and pull the rear derailleur gently backwards by hand - refer to the section on the “Derailleur gears” in the chapter on “Propulsion”.

Fig. 3/44 Source Enviolo

Removing the tyres



The tyres, rims and rim tapes must be checked after removing the wheel. There must be no sharp objects inside the tyre. The rim must not have any cracks or surface damage, and the rim tape must completely cover all spoke nipples and spoke holes. Damaged components must be replaced.

Unscrew the valve cap and the valve nut from the valve and deflate the tube completely by pressing down on the tyre. Use a tyre lever and position it on the lower edge of the tyre. On no accounts should you use sharp objects. Now pull the tyre sidewall up and over the rim („Fig. 4/ Source Schwalbe“ on page 44).

Use a second tyre lever at an interval of around 10 cm from the first one. Now push one of the tyre levers around the entire circumference of the rim. Then you can remove the tube („Fig. 5/ Source Schwalbe“ on page 44).

Fig. 4/44 Source Schwalbe

Fig. 5/44 Source Schwalbe

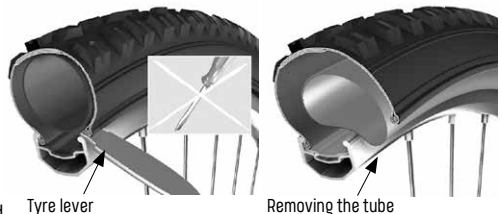

Fitting the tyres



- On no accounts may the tube become caught between the tyre and the rim („Fig. 1/ Source Schwalbe“ on page 45).
- If the air pressure in the tyre is too high, it may detach from the rim while you are riding or damage the rim.
- The air pressure information on the tyre and the rim must not be exceeded. The lower maximum value in each case is the maximum permissible air pressure. If the air pressure is too high, the tyre may detach from the rim while you are riding or the tyre and rim might become damaged.

Make sure that no foreign materials or dirt can enter the inside of the tyre when fitting a new or repaired tube.

Pull one side of the tyre onto the rim.

Then inflate the tube until it is round. Insert the valve through the hole on the rim and then place the tube into the tyre. Make sure that the valve is perpendicular to the rim („Fig. 2/ Source Schwalbe“ on page 45) and tighten the valve nut slightly.

Use a tyre lever to pull the other side of the tyre onto the rim. Start at the opposite side to the valve and continue evenly along the entire circumference of the rim.

After fitting the tyre, inflate the tube according to the instructions on the tyre and rim – refer to the section on the “Tyres, rim, tube”.

Mounting the wheel



- After mounting the wheel, fix the thru axle, i.e. the quick release and the hub axle nut, in place – refer to the chapter on “Recommended tightening torque”.
- All braking surfaces must be free of oil and grease.
- Before using the bicycle again, follow the instructions provided in the chapter on “General instructions”, section “Before every ride”.

The wheel is mounted in the opposite sequence to the descriptions in the individual sections on “Removing the wheel”, depending on the type of brake or drive system. The wheel must be positioned exactly in the designated slots on the fork or frame. Make sure that the thru axle, i.e. the quick release, is in the right place – refer to “Handling thru axles” and “Handling quick releases”.

If mechanical rim brakes are installed, it is essential to reattach the brake cable to the brake arm after mounting the wheel – refer to the chapter on the “Brake system”, section “Mechanical rim brakes”.

If hydraulic rim brakes are installed, it is essential to fit the brake cylinder back on the retainer once the wheel has been mounted. Close the quick-release lever to attach the brake – refer to the chapter on the “Brake system”, section “Hydraulic rim brakes”.

The brake pads on disk brakes need to be checked before fitting the wheel. Check that the brake pads are positioned correctly in the brake calliper and check them also for wear – refer to the chapter on the “Brake system”, section “Disk brakes”.

When dealing with hub gears, it is necessary to insert the cable housing into the cable housing on the hub after mounting the wheel. The mounting screw on the shift cable must also be locked into the shifting unit on the hub. When dealing with rear wheels fitted with a coaster brake, it is essential to fix the centre bolt to the chain stay – refer to the section on “Removing the wheel for hub gears” and the chapter on the “Brake system”, section “Coaster brakes”.

Check that the chain tension is correct after mounting the wheel – refer to the chapter on “Propulsion” in the section on the “Chain”.

Fig. 1/45 Source Schwalbe

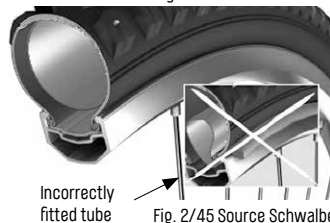

Incorrectly fitted tube

Fig. 2/45 Source Schwalbe

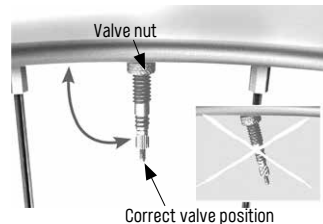

Correct valve position

Suspension elements:



- Expertise and special tools are always required to make adjustments to the suspension elements like the suspension fork, shock and suspension or height-adjustable seat post or to perform maintenance and care. Ask your KTM dealer to carry out all work and check your bicycle according to the instructions provided in the chapter on “*Maintenance and Care Intervals*”.
- Always adhere to the safety and other instructions in the component guides issued by the individual suspension element manufacturer.
- Suspension elements must be adjusted to the rider’s weight, sitting posture and intended use to ensure they work perfectly. Ask your KTM dealer to make all these adjustments before handing over your bicycle.
- On no accounts should suspension elements bottom out. Sudden and complete compression of the total suspension travel indicates that the air pressure is too low or the spring stiffness of the suspension fork, the shock or the suspension seat post is inadequate. The impact caused by this process may be transmitted to other components and lead to dangerous situations.
- Many suspension forks and shocks have the option using a locking mechanism (lockout) to block the suspension travel. Only use this function on even terrain and never in offroad terrain. There is the risk that you may lose control of your bicycle.
- Please be aware that your suspension fork and shock may be damaged when the lockout is closed. The suspension fork or shock is not completely rigid on some models and yields a little when force is applied, even if the lockout is closed.
- Do not turn screws if you are unaware what they control. You might release a mounting mechanism.
- It will not be possible to cushion a quick succession of obstacles if shock attenuation is too high on the suspension fork or the shock. In contrast, the bike will start to jump if the shock attenuation is too weak. This may also become dangerous.
- On no accounts may the tyres touch the suspension fork or the frame if the suspension fork or the shock compresses completely. The tyres may block.

Definitions

Term	Explanation
Spring stiffness	Spring stiffness is the necessary force to compress the spring a certain amount. A higher rate translates into greater spring stiffness and therefore more force per travel. This is equivalent to greater pressure in air suspension elements.
Spring characteristic	This describes the breakaway torque, suspension travel utilisation and bottom out protection of a suspension fork or shock. The spring characteristic is usually presented as a curve.
Spring pre-load	The preload on steel springs means that the spring action only responds at a higher load. This does not affect the spring stiffness.
Compression damping	Compression damping reduces the speed of compression.
Rebound damping	Rebound damping reduces the speed of extension.
Negative suspension travel	Negative suspension travel means the distance by which the suspension fork or the shock compresses when the rider assumes a customary sitting position while the bicycle is stationary.
Remote	This small shift lever on the handlebars is used to lock the fork or damper and therefore adjust the riding behaviour to suit the terrain.
Lockout	This term describes locking the fork/damper. Minimal suspension travel is still possible when the lockout is closed to protect the fork and damper from damage.

Suspension forks

Adjusting the spring stiffness

Almost every KTM bicycle comes equipped with a suspension fork. The mechanism significantly improves riding characteristics and control on rough terrain or uneven paths. It also reduces the strain exerted on other bicycle components and the rider. The suspension element in the fitted forks are either steel springs or air, while oil or friction are generally used for attenuation.

The fork must compress slightly by the negative suspension travel as soon as the rider assumes a seated position; it does so to compensate uneven ground (e.g. potholes) by means of the fork extension. This effect will not occur if the spring preload or the air pressure is too high, as the fork will already be fully extended.

The negative suspension travel is set to be shorter or longer, depending on the intended use. The suspension fork on a bicycle belonging to the cross country, trekking, city and marathon categories must compress by around 10–25% of the maximum suspension travel as soon as the rider assumes a seated position. This value should be approx. 20–40% for the gravity, freeride and downhill categories („Fig. 1/ Source Fox“ on page 47). It is important to note that the riding characteristics will differ very considerably, depending on the fork settings. Read the enclosed instructions for detailed information.

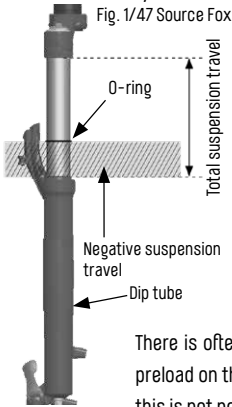

Determining the negative suspension travel for air forks

1. Let the air out of the fork to determine the total suspension travel.
2. Inflate the fork to the recommended air pressure.
3. Push the O-ring all the way down. If your fork does not have an O-ring, use a tie-wrap strapped tightly around the down tube.
4. Assume your customary seated position on the bicycle and support yourself against the wall.
5. Dismount from the bicycle without allowing the suspension to extend.
6. Measure the gap between the O-ring or tie-wrap and the uppermost edge of the dip tube. Compare this value with the fork's total suspension travel.

There is often a dial at the top of the fork leg on forks with steel springs. This dial is used to alter the preload on the spring and therefore the negative suspension travel. The steel spring must be replaced if this is not possible.

Air fork manufacturers specify the air pressure for each model and area of use. The instructions supplied by the suspension fork manufacturer contain further information. Regularly check the air pressure in your fork. Also refer to the chapter on "Maintenance and care intervals". The air pressure is usually checked using a special pump, which can be purchased from your dealer. Do not use a conventional air pump, e.g. for tyres, as it will be designed for larger capacities and may damage the suspension fork. There are retrofit kits available for many suspension fork models if the adjustment options are insufficient for you. Simply contact your KTM dealer. Only use matching and labelled, original spare parts when replacing components.

Adjusting the shock attenuation

Valves on the inside of the fork regulate the shock attenuation. They control the flow of oil. The speed at which the suspension fork compresses or extends changes. It is therefore possible to optimise the fork response for various obstacles. Blocking the shock attenuation can also reduce the rocking motion while pedalling. But shock attenuation must be open to a degree at least when you are riding downhill or offroad. Shock attenuation is adjustable on many suspension forks. Extension speed is adjusted by means of the rebound. The instrument to set the speed may be located on the underside of the dip tube („Fig. 2/ Rebound source: Fox“ on page 47) or on the fork crown. The corresponding adjustment knob is usually red.

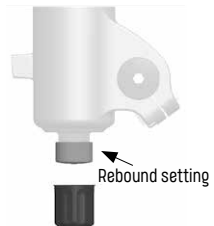

Fig. 2/47 Rebound source: Fox

Adjust the rebound settings to suit your needs and your preferred area of use. If the adjusting screw is closed (clockwise rotation), the oil inside the fork flows too slowly. This increases attenuation acting on the fork. A quick succession of bumps in the terrain will not be compensated fast enough.

Turning the adjusting screw to open (anti-clockwise rotation) will weaken shock attenuation and the fork will work faster on uneven ground.

Setting the compression level influences the speed of compression. Compression is adjusted on the fork crown. The adjustment knob is usually blue.

To change the compression, suspension forks can be fitted either with an adjustment dial or a 3-position lever („Fig. 1/ Compression source: Fox“ on page 48).

If the compression is very tight (clockwise rotation), the fork will offer a hard response. Turning the dial anticlockwise sets the compression to a softer response.

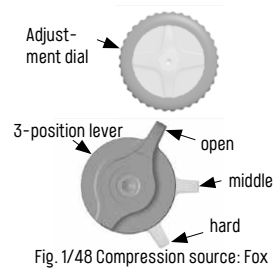

Shocks

Besides a suspension fork, many bicycle models come with a second suspension element, namely the shocks, which keep the tail mobile. The mechanism improves control of your bicycle on rough terrain or uneven paths. Shock tend to use an air spring. Like with suspension forks, oil takes care of the shock attenuation.

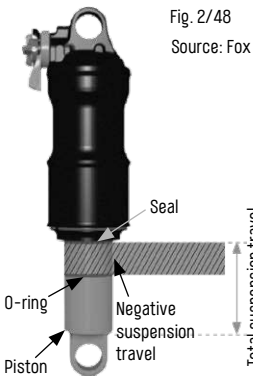

Determining the negative suspension travel for shocks

1. Let the air out of the damper to determine the total suspension travel.
2. Inflate the damper to the recommended air pressure.
3. Push the O-ring – or optionally a tie-wrap wrapped firmly around the piston – all the way down.
4. Assume your customary seated position on the bicycle and support yourself against the wall.
5. Dismount from the bicycle without allowing the suspension to extend.
6. Measure the gap between the O-ring or tie-wrap and the seal on the damper. Compare this value with the damper's total suspension travel.

The shock on a bicycle belonging to the cross country, trekking, city and marathon categories must compress by around 10–25% of the maximum suspension travel as soon as the rider assumes a seated position. This value should be approx. 20–40% for the gravity, freeride and downhill categories. The smaller the negative suspension travel, the harder the shock attenuation, making it better for even terrain like roads. Shock manufacturers specify the air pressure for each model and area of use. Adhere to their recommendations and read the component instructions provided by the individual manufacturer. Regularly check the air pressure of your shock by making sure that the O-ring is correctly positioned on the damper piston. The shock must not bottom out. This is usually indicated by a clear sound. Over time, bottoming out the shock may damage the frame or the damper. You must replace the damper if the adjustment options are insufficient for you. Retrofit kits are available for some shock models. Only use matching and labelled, original spare parts when replacing components.

Adjusting the shock attenuation

Valves on the inside of the shock regulate the shock attenuation. They control the flow of oil. The speed at which the damper compresses or extends changes. It is therefore possible to optimise the damper response for various obstacles. Blocking the shock attenuation can also reduce the rocking motion while pedalling. But shock attenuation must be open to a degree at least when you are riding downhill or offroad.

The rebound and hence the compression response of the damper can be adjusted for many shocks. The adjustment knob on the damper is used for this purpose („Fig. 1/ Source Fox“ on page 49).

Adjust the rebound settings to suit your needs and your preferred area of use. If the adjusting screw is closed (clockwise rotation), the oil inside the damper flows too slowly. The shock effects greater attenuation. A quick succession of bumps in the terrain will not be compensated fast enough.

Turning the adjusting screw to open (anti-clockwise rotation) will weaken shock attenuation and the damper will work faster on uneven ground.

Setting the compression level influences the speed of compression. Compression is changed using the adjusting lever. To change the compression, the shock can be fitted either with an adjustment dial or a 3-position lever („Fig. 2/ Source Fox“ on page 49).

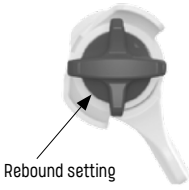

Rebound setting
Fig. 1/49 Source Fox

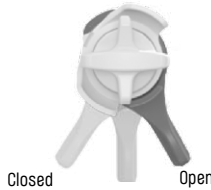

Closed
Open
Fig. 2/49 Source Fox

The damper shows a hard response if the compression is closed. The damping response is softer if the compression is open.

Maintenance of suspension elements

The suspension fork and the shock are complex components. A certain degree of maintenance and care is necessary to ensure they work faultlessly. The service intervals depend strongly on the manufacturer of the fork/damper. Refer to the manufacturer's instructions for more information.

Some maintenance is the same for all manufacturers:

- Make sure that the sliding surfaces of the fork down tubes and the damper piston are always free of dirt. Use water and a soft sponge to clean the fork and the damper after each excursion. Then spray the down tubes and the piston with a suitable lubricant.
- Bring the bicycle to your KTM dealer for regular inspections of all screw connections on the fork and damper – refer to the chapter on “*Maintenance and care intervals*”.
- Regularly check the air pressure in the fork and shock. Air may gradually escape over time – refer to the chapter on “*Maintenance and care intervals*”.
- Regularly check the shock for horizontal bearing clearance. Grasp the saddle and lift up the bicycle, then move the rear wheel to the left and the right. Consult your KTM dealer to repair the problem if you notice any bearing clearance.
- Regularly check the shock for vertical bearing clearance. To do this, lift the rear wheel slightly and then replace it gently on the ground. Listen for any clicking sounds. Consult your KTM dealer to repair the problem if you notice any bearing clearance.

Suspension seat posts



- Pay attention to the minimum and maximum insertion depth for the seat post. The frame may break if the seat post is not inserted far enough.
- Do not release the adjusting screw too far.

Suspension seat posts are more comfortable on uneven terrain. But they do not offer the benefits of a frame with full suspension frame. The spring tension of the seat post can be changed to achieve the desired characteristics („Fig. 1/ Source Suntour“ on page 50):

- Remove the seat post from the frame to alter the spring tension.
- The adjusting screw to tension the spring is on the underside of the post.
- Turn the adjusting screw clockwise to increase the tension.
- Turn the adjusting screw anticlockwise to reduce the spring tension.

Check regularly for post clearance. Grip the front and rear of the saddle and move it in all directions. Consult your KTM dealer if you notice any significant clearance.

There are other types of suspension seat posts as well, which are shown in „Fig. 2/ Source Suntour“ on page 50. As a rule, all moving, articulated connections must be lubricated regularly to ensure their durability and good working order.



Fig. 1/50 Source Suntour



Fig. 2/50 Source Suntour

Height-adjustable seat posts



- For height-adjustable seat posts, only adjust the correct saddle height after the seat post has been fully extended.

Height-adjustable seat posts are used to change the seating position to suit the intended use and terrain. An operating lever on the handlebars is used to make the adjustment. The lowering mechanism can be activated hydraulically or mechanically.

To lower the saddle, push down on it with your hand or sit on it while pressing and holding the operating lever. Release the lever when you have reached your preferred height.

Press the operating lever on the handlebars to raise the saddle. Remove the pressure on the saddle and release the lever when the desired height is reached. You can raise or lower your saddle to any height that the length of your seat post permits.

Lighting



- Expertise and special tools are always required to make adjustments to the lighting or to perform maintenance and care. Ask your KTM dealer to carry out all work and check your bicycle according to the instructions provided in the chapter on "Maintenance and Care Intervals".
- Adhere to the safety instructions in the lighting manufacturer's component instructions.
- Check the battery charge if your lighting is battery-powered.
- You are breaking the law if your lighting does not work or is incomplete (regulations may differ, depending on the country). Riding bicycles without lighting in road traffic presents a mortal danger as they can be easily overlooked - refer to the chapter "General Instructions".

If equipped with daytime running lights, riders can switch the head lights to suit the prevailing light conditions, in addition to the "on" and "off" settings. The lights can switch from day to night mode, depending on the light conditions. The signal LEDs operate at full capacity in day mode, and the main head light shows dimmed brightness. The main head light operates at full capacity in night mode.

There is an additional switch with a light symbol on the handlebars for head lights with high beam. This switch is used to switch between dipped lights and high beam. Be aware that other road users may be dazzled by your high beam. Deactivate the high beam function as soon as possible if this may happen.

In general, the dipped head lights should be adjusted so that the light strikes the road at a slightly oblique angle (Fig. 1/ Light adjustment" on page 51). But the light must not be so far forward that it can become a nuisance to other road users. Please take note that some countries (e.g. Germany) only permit the operation of head lights that have been awarded a "K" test mark.

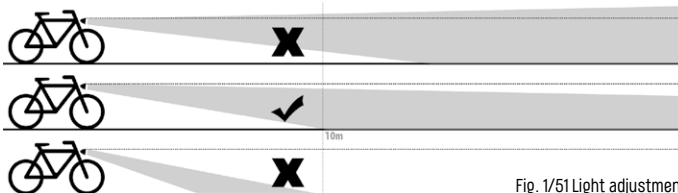

Fig. 1/51 Light adjustment

An acceleration sensor analyses the braking strength for rear lamps with brake light function. This permits a distinction normal operation, braking and - in special rear lamp versions - emergency braking. For example, an additional brake light on the rear lamp switches on during braking. In addition, emergency braking can be signalled by an additional flashing emergency brake light.

Lighting on the EPAC

The current is supplied by the EPAC drive unit battery (direct voltage DC). The light output is supplied with 6V or 12V, depending on the model and design of the drive unit. If you want to change your lighting system, please contact your KTM dealer who has the necessary software to adjust the head light to the output voltage.

Lighting on the bicycle

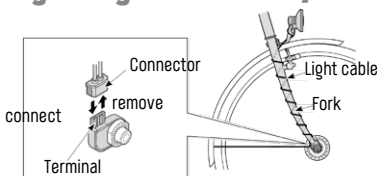

Fig. 2/51 Hub dynamo terminal
Source: Shimano

The hub dynamo in the front wheel hub supplies the current. It operates as an extremely low-wear and high-efficiency electric generator. The lighting connector must be fixed in place using a terminal (Fig. 2/ Hub dynamo terminal" on page 51). Viewed in the direction of travel, the terminal is located on the right-hand side of the hub. You must disconnect the plug when removing the front wheel. Make sure that the light cable is in a flawless condition.

In the case of hub dynamos, dirt often accumulates or corrosion may form between the connector and the terminal. Disconnect the connector and clean the connection. Then reconnect the connector with the terminal.

Headset



- Expertise and special tools are always required for all adjustments, maintenance and care of your headset. Ask your KTM dealer to carry out all work and check your bicycle according to the instructions provided in the chapter on “*Maintenance and Care Intervals*”.
- A loose headset increases the load on the fork and other components.
- Excessive tightening of the bearing may destroy the headset.

The headset is the bushing on the fork and connects it to the head tube. The headset must work smoothly, but without bearing clearance. The headset is exposed to stress when travelling on undulating paths or across uneven ground, which may cause it to loosen. It is therefore essential to check the headset bearing clearance regularly – refer to the chapter on “*Maintenance and care intervals*”.

Checking the bearing clearance

Place your hand around the gap between the fork and the head tube. Use your other hand to press the front brake at the same time. Gently push the bicycle back and forward several times. You will notice clearly if there is bearing clearance in the headset. Then lift the front wheel. Allow it to drop to the ground from a low height. You will hear an unusual sound when the front wheel hits the ground if there is bearing clearance in the headset.

Also check that the headset runs smoothly when the front wheel is raised. To do this, move the handlebars back and forth in both directions. The handlebars must turn smoothly and without recoil. Make certain as well that the stem is mounted firmly. Grasp the front wheel between your legs. Try to twist the handlebars. If necessary, tighten the screws on the stem according to the instructions provided in the chapter on “*Recommended tightening torques*”.

Bolted headset

The stem is inserted inside the steer tube in this kind of headset. A stem spindle is used to clamp the stem firmly into the steer tube. The bearing clearance is adjusted using a bearing cup and a matching lock nut.

Ahead headset

In this kind of headset, the stem is not inserted into the steer tube, but grasps the steer tube from the outside. The bearing clearance is adjusted by stem clamping. The headset bearing may be integrated in the frame. The headset will not be visible in this case.

The spacing ring and the fork therefore transition directly into the head tube on the frame. Nonetheless, the settings can be checked in the same way as for a conventional Ahead headset. To determine the bearing clearance, however, it is necessary to consider the transition from frame to fork in more detail.

Bottle holder

Bottle holders are used to keep drinking bottles in place and are fitted to the bottle hold eyelets on the bike frame. The following maximum loading weights on the bottle holder eyelets must be observed:

	Bicycle		EPAC	
	Frame	Frame	Battery cover	
			1 Mounting position	2 Mounting position
Aluminium	1.0 kg	1.0 kg	1.5 kg	1.5 kg + 0.5 kg
Carbon	1.0 kg	1.0 kg	1.5 kg	1.5 kg + 0.5 kg

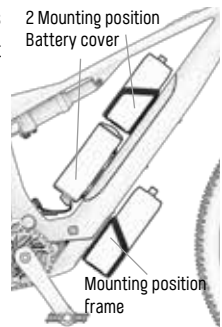

Only some battery covers have two mounting positions for simultaneous installation of a range-extending additional battery and a bottle holder. Your KTM dealer will gladly assist you in selecting and mounting the right components.

Fig. 1/52 Examples of mounting positions for EPACs

Particular properties of carbon material

Carbon is a carbon fibre-reinforced polymer and has special properties.

- A regular and thorough visual inspection of the frame and fork must be performed regularly to identify any damage (e.g. cracks, discolouration). Impact or shocks can cause damage that in most cases will not be visible on the exterior. This may include delamination (detachment of the fibres from the surrounding resin matrix) in lower laminate layers, leading to a drastic reduction in performance and therefore safety as well.
- For safety reasons, the frame and fork must no longer be used after an accident, fall or similarly excessive mechanical load.
- The instructions issued by the individual manufacturers for mounted components must be adhered to in every event. Delamination may occur on carbon components like the handlebars, stems or seat posts if the bolts are excessively tightened at the connection points. Adhere to the specified tightening torques for the components as stated in the chapter "Recommended Tightening Torques" or ask your KTM dealer.
- Damaged carbon components must not be repaired. The safety risk is too large. Immediately replace any damaged carbon components.
- On no accounts may you expose carbon materials to excessive temperatures. Never repaint or powder coat frames, forks or other mounted parts.
- Only use mounted parts and components that have been approved for use with carbon frames and that have the correct dimensions. Only use special tools to fit parts. Adhere strictly to the specified torques as stated in the chapter "Recommended Tightening Torques".
- KTM carbon frames are not suitable for training on fixed rollers (e.g. Elite). They can run on rollers without fixed mounting.
- Mounting surfaces (seat tube, steer tube, etc.) must not be greased. In these cases, only apply special mounting pastes for carbon parts to the surfaces. Seat tubes and bearing seats must not be sanded, re-milled or otherwise mechanically processed.
- As a precautionary measure, it may be necessary to replace load-bearing components such as the handlebars, stems or seat posts in regular intervals (every 2 years). Your KTM dealer will gladly offer advice.
- Never use transport systems and mounting stands with clamp mechanisms. The atypical load exerted by the clamping mechanism may damage or destroy the frame.
- Protect areas of the carbon frame that are particularly susceptible to damage, especially the underside of the down tube and the areas where the gear or brake cables rub. Your KTM dealer can obtain special stickers to protect the frame. There are also special stickers for the chain stay to prevent the chain from being damaged on the frame/paint.
- Never store carbon parts close to heat sources. Also do not leave carbon parts for extended periods in your car on particularly sunny days. High temperatures can damage the material.
- Always ensure that carbon bicycles or components are properly protected during transport by car. Use foam, blankets or similar items to pad the materials.
- Never use trailers, racks or child seats in connection with a carbon frame.
- The seat posts must be dismantled regularly and then refitted with mounting paste.
- Under no circumstances should carbon frames be engraved, as doing so may negatively affect frame stability and can cause the frame to break – refer to chapter "Warranty and Guarantee".

Bicycle transport

Bicycle transport by car



- The roof and rear racks must comply with the applicable safety standards in your country.
- Remove all additional attachments such as panniers or child seats when transporting your bicycle on a roof or rear rack.
- Bicycles made of carbon are not suitable for transport on roof or rear racks on cars. The clamping mechanism may damage the frame material.
- Bicycles without round tubes at the mounting position are not suitable for transport on a roof or rear rack. The necessary clamping force cannot be applied.
- Make sure that brake lines and shift cables are not damaged during transport (see “Adjusting the bicycle” on page 24 “Handlebar height and stem settings” on page 26)
- EPACs may be subject to different requirements due to the national regulations on hazardous goods.

Transporting your bicycle in the boot of your car protects it from external influences. A variety of alternative transport solutions are available if your boot is not suitable to fit a bicycle.

Roof racks



- Always consider the increased aggregate height of your vehicle due to the bicycle on the roof rack. Measure the aggregate height of your vehicle and write it down so that you do not cause accidents or obstruct traffic at underpasses and such like.

When using a roof rack, the tyres of the bicycle are placed in a track and a holding device is clamped to the down tube of the frame. The frame tube must not be compressed during the clamping process.

Rear racks



- Pay attention to the permissible payload of the rear rack and adhere to any mandatory speed limit as applicable.
- Make sure that the license plate and lighting on your car are not concealed. National laws may require you to fit an additional wing mirror/license plate holder.

Rear racks are attached to the trailer hitch on the car. When using a rear rack, the tyres of the bicycle are placed in a track and a holding device is clamped to the top/down tube of the frame.

Bicycle transport by train

Enquire about the formalities before embarking on your trip. Also state during reservation that you will be travelling with your bicycle. Remove all carriers and accessories from your bicycle during the journey protect to them from damage or theft.

Bicycle transport by plane

You must pack your bicycle in a suitable bicycle case or box to transport it by plane. But do not pack any bicycle panniers as they will not be adequately protected. Deflate the tyres, remove the wheels and pack them in special wheel bags. Pack all the tools you need, including a torque spanner and suitable bits, to get your bicycle operational when you reach your destination. Take these instructions in order to refer to the relevant chapter if anything is unclear. If disk brakes are fitted to your bicycle, the brake pads must be secured with a pad retainer after removing the wheel. The pad retainer was included when you purchased your bicycle. Use a rubber band to pull the brake levers towards the handlebars to ensure that air cannot enter the brake system. It is also advisable to contact the airline and clarify any issues before embarking on your journey.

Bicycle equipment

Bicycle helmet



- Always wear a tested bicycle helmet when using your bicycle.
- Adjust the fit and the length of the strap to suit your head.
- Wear a freeride helmet, as well as pads and protectors, if this is required for the intended use according to the chapter on “*Intended use*”.
- Children travelling in a child seat or a bicycle trailer should also wear a suitable, tested helmet.

Bicycle helmets („Fig. 1/ Bicycle helmet“ on page 55) are indispensable items of safety equipment due to today’s traffic situation and the diverse areas in which bicycles are used. This remains true, even if they are not mandatory in individual countries. Bicycle helmets need to fit properly. Wear the helmet for a little while before buying one. This way you can tell whether the helmet is comfortable and sits tightly. The helmet must have passed a standardised testing procedure in accordance with the respective national guidelines.



Fig. 1/55 Bicycle helmet

Shoes and pedals



- Expertise and special tools are always required to make adjustments to the shoes and the pedals or to perform maintenance and care. Ask your KTM dealer to carry out all work and check your bicycle according to the instructions provided in the chapter on “*Maintenance and Care Intervals*”.
- Always adhere to the safety and other instructions in the component guides issued by the individual shoe and pedal manufacturer.
- Familiarise yourself with how the pedal works in a safe area without much traffic. Practice using the shoe release mechanism in particular.
- Make sure that the pedal and the holding plates on the shoe are always tightly connected and free of dirt. This makes it easier to lock the shoe safely into the pedal. Holding plates may become worn and will need to be replaced in this case.

Cycling shoes need to have a robust design. The sole area in particular should be stable so that the pedal does not dig noticeably into the bottom of the shoe. Some bicycles may be fitted with special system pedals. In turn, special cycling shoes are required for these kinds of pedals. Holding plates on the soles connect these shoes firmly with the pedals. This enables fast pedalling and also makes certain that the foot retains a firm purchase on the pedal when riding on uneven terrain. Force transmission is extremely direct as well. But riders can still detach their feet easily from system pedals.

The holding plates are fitted to the shoe around the ball of the foot. They lock into place by moving the foot forward, i.e. downward, into the pedal („Fig. 2/ Source Shimano“ on page 55). But the foot is released from the pedal by turning the ankle („Fig. 3/ Source Shimano“ on page 55). The release force can be adjusted directly on the pedal by changing the spring pre-load. Your KTM dealer would gladly help you to find the ideal shoe for your pedals. If the pedal emits a squeaking or clicking sound, this can usually be alleviated by applying a suitable lubricant to the contact points of the shoe and pedal.

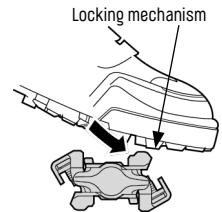

Fig. 2/55 Source Shimano

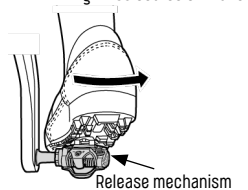

Fig. 3/55 Source Shimano

Maintenance and care instructions



- Have your bicycle inspected by your KTM dealer after the first 200 kilometres. The screw connections, cables and spokes on the wheels settle during these initial kilometres of use in particular.
- Bring your bicycle to the KTM dealer for inspection or repair at least once each year, depending on your mileage. Various components may otherwise fail.
- Only use original spare parts if you need to replace components.

Regular inspections as described in the chapter on “*Maintenance and care intervals*” will keep your bicycle in a safe operating condition at all times. Adherence to the prescribed inspections guarantees functionality and vastly increases the service life of the bicycle and the installed components.

Cleaning and care



- Never use steam jets or high-pressure cleaners to clean your bicycle. This could destroy the bicycle's bearings and seals.
- Look out for deformations, cracks or discolouration of the bicycle during the cleaning process. Ask your KTM dealer to replace damaged parts without delay.
- Never treat matte paints with polish.
- Do not allow lubricants and care agents to come into contact with the braking surfaces. This would severely impair the braking performance.
- Never introduce oils or greases into clamping areas made of carbon.
- Always use chemically neutral detergents to clean painted surfaces. Acidic or alkali detergents may attack the surface.
- Avoid detergents coming into contact with grips or other silicone/rubber-like bicycle components.

When cleaning your bicycle, check for wear on the chain as described in the chapter on “*Propulsion*”, section “*Chain*”. Apply a suitable lubricant to the chain after cleaning.

External influences like sweat and dirt may damage your bicycle. Clean all components regularly.

Storage and safekeeping



- Never suspend your bicycle from the rims if they are made of carbon. The rims may break.
- Many dealers offer promotional prices for annual inspections during the winter months. You will barely have to wait at that time of the year, either. Use this period to bring your bicycle for its annual inspection.

If a bicycle is regularly maintained, no special measures are required if it is parked for a short period. You should certainly fit a suitable mechanism to protect against theft. Keep your bicycle in a dry and well-ventilated place. Adhere to the following if you intend to mothball your bicycle for a longer period:

- The tubes in the tyres will gradually deflate. This may damage the tyre structure.
- Hang the wheels of the complete bicycle in a raised position above the ground. Check the tyre pressure regularly if this is not possible.
- Clean your bicycle before you mothball it for an extended period. This will protect it from corrosion. Ask your KTM dealer about suitable care and cleaning agents.
- Dismantle the seat posts. Any moisture that penetrates your bicycle can then evaporate.
- Shift to the smallest chainring at the front and to the smallest sprocket at the back. This relaxes the tension on all cables and springs.

Maintenance and care intervals

Arrange an appointment for inspection with your KTM dealer after you have ridden your bicycle for the first 200 km. The following table defines the subsequent maintenance intervals for each component. The inspection intervals are noted in the "Inspection Certificate" chapter. These inspection intervals must be shortened, sometimes considerably, if your bicycle is subject to heavy use, e.g. regular use in bad weather. Take note that aggressive environmental influences corrode the surfaces of your bicycle. This is unavoidable, regardless of how carefully the bicycle was finished by the manufacturer. Weekly cleaning is necessary in these cases. You can perform the activities marked in the "Customer" column yourself. Contact your KTM dealer if you are unsure about maintenance or servicing. Activities marked in the "Dealer" column must only be performed by your KTM dealer.

Component	Activity	Maintenance interval	Performed by	
			Customer	Dealer
Lighting	Function check	Before every ride	X	
Tyres	Check air pressure	Before every ride	X	
	Check tread	Monthly	X	
	Check side walls (cracks)	Monthly	X	
Brakes	Check lever travel / Check pad thickness / Stationary brake test	Before every ride	X	
	Clean	Monthly	X	
Suspension fork	Check screw connections	Annually		X
	Oil change	Annually		X
Rims with rim brakes	Check wall thickness	After the second replacement of brake pads at the latest		X
Inner bearings	Check bearing clearance	Monthly	X	
	Grease housing	Annually		X
Chain	Lubricate	Before every ride	X	
	Replace	After 1,000+ km		X
Chainrings	Check and replace	Between 1,500 km and 3,000 km		X
Crank	Tighten screws	Monthly	X	
Paint and carbon	Treat surface	6-monthly	X	
Wheels	Check trueness	Monthly	X	
Handlebars	Check and replace	After 2 years at the latest		X
Metal surfaces	Treat surface (do not treat the braking surfaces)	6-monthly	X	
Inner bearings	Check bearing clearance	Monthly	X	
Hubs	Check bearing clearance	Monthly	X	
	Grease	Annually		X
Pedals	Check bearing clearance	Monthly	X	
	Lubricate locking mechanism	Monthly	X	
Seat post	Check screws	Monthly	X	
	Grease	Annually		X
Rear derailleur	Clean and lubricate	Monthly	X	
Quick release	Check tight fit	Before every ride	X	
Screws and nuts	Check and tighten	Monthly	X	
Spokes	True and tighten	Whenever necessary		X
Rigid fork	Check and replace	After 2 years at the latest		X
Thru axle	Check tight fit	Before every ride	X	
Headset	Check bearing clearance	Monthly	X	
	Grease	Annually		X
Derailleur	Clean and lubricate	Monthly	X	
Valves	Check tight fit	Before every ride	X	
Stem	Check and replace	After 2 years at the latest		X
Sprocket	Check and replace	Between 1,500 km and 3,000 km		X
Cables (shifting system/brake)	Dismantle and grease	Annually		X

Recommended tightening torques



Never exceed the torque specified by the manufacturer of the individual component, as it may otherwise break completely. Refer to the following tables for more information. Also adhere to any information provided directly on the component, if applicable.

Making certain that components are screwed in place correctly will ensure the operational safety of your KTM bicycle. Check the connections regularly. Always use a torque spanner that indicates when the correct tightening torque is applied. Increase the torque incrementally, ideally in steps of half a newton metre. Check the firm connection of your component now and then. If no precise details are provided for certain components, start with a torque of 2 Nm. Also adhere to any information provided directly on the component and in the instructions supplied by the individual component manufacturer.

Stems

Component	Fork side	Handlebar side
ERGOTEC SWEEL, HIGH CHARACTER	6-8 Nm	6-8 Nm
ERGOTEC PIRANHA 2	9-11 Nm	6-8 Nm
ERGOTEC SEPA XL	10-12 Nm	6-8 Nm
KTM PRIME (HRS -02R)	5 Nm	5 Nm
KTM TEAM (Kailoy AS-KT-6, AS-82J)	5-7 Nm	5 Nm
KTM TEAM (JD-ST199A, Vipea7)	5-6 Nm	5-6 Nm
KTM TEAM TRAIL (ATB-957)	6 Nm	6 Nm
KTM COMP (JD-S192A, Sidewinder)	5-6 Nm	5-6 Nm
KTM COMP (JD-S158A)	6 Nm	6 Nm
KTM LINE (Satori: UP+, Satori: UP3, Rana)	9-10 Nm	5-6 Nm
KTM LINE (AS-007N, APT-H501)	5-7 Nm	5 Nm
KTM LINE (Fastback, Python)	5-6 Nm	5-6 Nm
KTM FOLD BANZEI	10-12 Nm	8-9 Nm
FSA ROAD NS ACR	6 Nm	6 Nm
FSA MTB NS ICR	6 Nm	5 Nm

Frame

Component	Screw connection	Torque
Bottle boss screws	Frame	Aluminium: 5 Nm/ Carbon: 4 Nm
Shocks	Damper on the frame	8 Nm
Chain stay deflector	Main frame deflector	10 Nm
Lisse gearbox cover	Frame	2 Nm
Frame swing arm	Main frame chain stay	20 Nm
Dérailleurs hanger	Frame	20 Nm

Pedals

Component	Screw connection	Torque
Shimano pedal	Mounted on the crank arm	35-55 Nm
Shimano pedal	Holding plates on the shoe	5-6 Nm
VP / Wellgo pedal	Mounted on the crank arm	35 Nm

Saddle clamps

Component	Screw connection	Torque
KTM Line JD-SC74 / JD-S039 / JD-S054 / Cl-KE06E-CV	Seat post clamping	Max. hand force
KTM Line JD-SC140A	Seat post clamping	6 Nm
KTM Team Light Cl-F121	Seat post clamping	4 Nm
KTM Prime (L120/L114 Carbon REV, AUTO (KTM 28-P109810))	Seat post clamping	5 Nm

Seat posts

Component	Screw connection	Torque
bySchulz	Saddle clamping	12-14 Nm Grub screw: 3 Nm
FOX TRANSFER FACTORY / PERFORMANCE	Saddle clamping	6-8 Nm
FOX TRANSFER NEO FACTORY	Saddle clamping	5 Nm
KTM PRIME (Saso P00228)	Saddle clamping	6 Nm
KTM TEAM (SP-719KT / Kailoy SP-619)	Saddle clamping	12 Nm
KTM COMP (Satori SP-D0K)	Saddle clamping	10 Nm
KTM COMP (JD-VSP1BP, JD-VSP3Z2, JD-VS16S, JD-VS134)	Saddle clamping	8-10 Nm
KTM COMP parallelogram	Saddle clamping	8 Nm
KTM LINE (Kailoy SP-612)	Saddle clamping	Side screw: 8 Nm Lower screw: 12 Nm
KTM LINE (Satori ELEGANCE LT)	Saddle clamping	9-10 Nm
KTM LINE (Satori SP-356)	Saddle clamping	18-22 Nm
KTM LINE (JD-VSP28)	Saddle clamping	8-10 Nm
KTM FOLD BANZEI	Saddle clamping	9 Nm
RITCHEY PRO / COMP	Saddle clamping	14-16 Nm
ROCK SHOX REVERB AAS	Saddle clamping	12 Nm
ROCK SHOX REVERB	Saddle clamping	8 Nm
SUNTOUR NOX	Saddle clamping	15-18 Nm
X-FUSION MANIC	Saddle clamping	8 Nm
SPIN-HOT	Saddle clamping	6 Nm

Crank and inner bearings

Component	Screw connection	Shimano	Sram	Miranda	FSA
Inner bearings	Housing (rectangular)	49-69 Nm			
Inner bearings	Housing (Hollowtech II)	35-50 Nm			
Inner bearings	Housing (Octalink)	50-70 Nm			
Inner bearings	Housing (GXP)		34-41 Nm		
Crank	Mount rectangular / Octalink	35-50 Nm			
Crank	Left crank arm (Hollowtech II)	12-14 Nm			
Crank	End cap (Hollowtech II)	0.7-1.5 Nm			
Crank	Mount (GXP)		48-54 Nm		
Crank	Mount (ISIS)		57-64 Nm	48-54 Nm	
Crank	Mount (BNI / Mini-ISIS)		57-64 Nm		
Crank	Large / middle chainring	12-14 Nm			
Crank	Small chainring	16-17 Nm			

Brake systems

Component	Screw connection	Shimano	Sram	Tektro	Magura
Hydraulic rim brakes	Mount frame/fork				6 Nm
Hydraulic rim brakes	Cable mount on the grip / brake calliper / handlebars				4 Nm
Disk brakes	Mount frame/fork	6-8 Nm	9-10 Nm	6-8 Nm	6 Nm
Disk brakes	Mount center lock disc	40-50 Nm			
Disk brakes	Mount 6-hole disc	2-4 Nm	6.2 Nm	4-6 Nm	4 Nm
Disk brakes	Cable mount on the grip	5-7 Nm	8 Nm		4 Nm
Disk brakes	Cable mount on the brake calliper	5-7 Nm	8.5-10 Nm		3 Nm
Disk brakes	Venting screw master cylinder	4-6 Nm	1.5-1.7 Nm		0.5 Nm
Disk brakes	Venting screw slave cylinder	4-6 Nm		4-6 Nm	4 Nm
Disk brakes	Mount brake pad	2-4 Nm	1 Nm	3-5 Nm	2.5 Nm
Disk brakes	Cable clamp brake calliper	6-8 Nm			
Disk brakes	Brake lever on the handlebars	6-8 Nm		5-7 Nm	4 Nm
Side-pull brakes	Mount frame/fork	5-7 Nm	8-10 Nm		
Side-pull brakes	Mount brake pad	5-7 Nm	5-7 Nm		
Side-pull brakes	Cable clamp / Brake-shift lever on the handlebars	6-8 Nm	6-8 Nm		
V-brakes	Mount frame/fork	5-7 Nm		8-10 Nm	
V-brakes	Mount brake pads / cable clamp / brake arm on the handlebars	6-8 Nm		6-8 Nm	

Propulsions

Component	Screw connection	Shimano	Sram
Brake-shift lever	Mount (handlebars)	6-8 Nm	6-8 Nm
Gear hub	Hub axle nut	30-45 Nm	30-40 Nm
Grip shifter	Mount (handlebars)	2-2.5 Nm	1.9-2.5 Nm
Shift lever	Mount (handlebars)	3 Nm	5-6 Nm
Shift lever	Mount (brake)	4 Nm	2.8-3.4 Nm
Rear derailleur	Mount (derailleur hanger)	8-10 Nm	10-12 Nm
Rear derailleur	Cable clamp	6-7 Nm	4-5 Nm
Rear derailleur	Guide rollers	2.5-5 Nm	2.5-5 Nm
Derailleur	Mount (frame)	5-7 Nm	5-7 Nm
Derailleur	Cable clamp	6-7 Nm	5-7 Nm
Sprocket	Circclip	30-50 Nm	40 Nm

Wheels

Component	Screw connection	Torque
E-Thru thru axle	Attaching the wheel	5-7.5 Nm
KTM thru axle	Attaching the wheel	10 Nm
KTM thru axle	Lever alignment	5 Nm
Maxle thru axle	Attaching the wheel	9-13.6 Nm
Magura thru axle	Attaching the wheel	10 Nm
Shimano hub	Front wheel nut	20-25 Nm
Shimano hub	Rear wheel nut	25-30 Nm
Enviolo hub	Rear wheel nut	30-40 Nm
Q-Loc thru axle	Attaching the wheel	10 Nm
Quick release	Attaching the wheel	5-7.5 Nm

Grips

Component	Screw connection	Torque
ERGON GE10 / GA20	Mount (handlebars)	3 Nm
ERGON GP1	Mount (handlebars)	4 Nm
ERGON GP30	Mount (handlebars)	5 Nm
KTM COMP	Mount (handlebars)	2 Nm

Warranty and guarantee

The KTM bicycle is state of the art. It is equipped with the best components by prestigious manufacturers.

This is a voluntary manufacturer's warranty issued by KTM. In the EU, consumers are given at least a two-year warranty period after handover of the item they purchased.

The KTM warranty extends to all material and workmanship defects for two years from the date of purchase.

KTM Bicycles guarantees at least 60% of the rated capacity for 400 Wh, 500 Wh, 600 Wh, 625 Wh, 750 Wh and 800 Wh batteries or 70% of the rated capacity for 300 Wh batteries during the warranty period (as defined below):

The warranty period for rechargeable batteries used for non-commercial purposes (so personal use) is defined as one of the following two cases, whichever is earliest:

- Within 24 months from the date of the first end user purchase OR
- Within 500 full charge cycles

Unless otherwise authorised in writing by KTM Bicycles, the warranty period for batteries used for commercial purposes is defined as one of the following two cases, whichever is earliest:

- Within 12 months from the date of purchase by the commercial user OR
- Within 500 full charge cycles

Damage due to improper handling or mounting is excluded from the warranty and warranty claims. Adhere in particular to the instructions in the chapter on "Intended use", which provides information on the maximum permissible weights, types of use and load limits for your KTM bicycle. It is the customer's sole responsibility to ensure regular maintenance and care of the bicycle (including adherence to all inspections in accordance with these operating instructions): regular care, maintenance and inspections extend the service life of your bicycle.

Furthermore, the following activities will also void the warranty:

- The model, serial or product number on the product has been altered, deleted, defaced or removed. Components have been altered or manipulated in regard to their specification. Protective seals on components have been broken open.
- Modifications have been made for which the KTM product was not originally approved.
- Modifications have been made to the product to ensure its compliance with local or national technical standards in countries for which the product was not originally approved by KTM.
- Batteries and electrical components have been used that are not compatible with or approved for the product. Chargers have been used to charge the batteries that were not provided together with the product or are not approved for the specific battery.
- Accidents, force majeure or causes beyond the control of KTM caused by water, fire, public disturbances or improper use or storage.

Warranty claims and complaints must be settled with the KTM dealer from which the bicycle was purchased. This will always require the presentation of proof of purchase in the form of an original purchase or cash register receipt stating the date of purchase, the dealer name and the model designation, including the bicycle's frame number. KTM reserves the right to refuse to perform warranty services if the documents are not submitted in full.

Legal claims for material defects against your dealer remain unaffected by this warranty. If your bicycle has a defect that was already present at the time of transfer of risk (the transfer of risk takes place when the bicycle is handed over to the buyer by the seller after the purchase is completed), the buyer can claim this defect from the seller within 2 years of this date; if a defect is discovered in the first 6 months after the transfer of risk, it is refutably assumed that the defect is a material defect. Normal wear and tear (e.g. on tyres, tubes, chains, sprockets, brake pads, paint job) and ageing in a customary extent do not constitute material defects, rather only initial defects that were present at the time of transfer of risk, irrespective of whether they are visible or concealed.

KTM does not provide any warranty for discolouration of the paint job. UV radiation causes certain colour changes in coatings and surfaces, and the composition of neon paint jobs in particular can cause these changes to occur more strongly or quickly. The structure of the carbon material is visible in carbon frames and carbon components with a transparent paint job. This is an intentional design element and not a defect. The patina may vary in intensity.

KTM shall not be liable for financial loss, downtime, rental or hire equipment, travel costs, loss of profit or similar. KTM's liability is limited to the purchase price of the product, with due consideration of a deduction depending on the age of the product. As a rule, KTM shall be entitled to repair or replace the product (subsequent performance) prior to any right to withdrawal or reduction in price. In the event of a warranty claim, KTM has the discretionary right to repair the defective component or replace it with a product that is equivalent in function. Components that are not defective will only be replaced on the account of the warranty holder. There is no right to an identical colour or design. As a rule, subsequent performance shall only be deemed to have failed after two attempts at subsequent performance have not been successful.

Warranty repairs are carried out at the KTM premises or by individual service partners. The costs of repairs that are carried out in advance by parties that are not authorised by KTM will not be reimbursed. The warranty shall be voided in this case. Repair services or replacements carried out under warranty do not lead to an extension of the warranty period or its re-commencement. Repairs and direct replacements carried out under warranty may be made using functionally equivalent replacement units.

Neither KTM nor its subsidiaries shall be liable for incidental or consequential damages or for breach of any statutory or contractual warranty with respect to this product. This warranty does not affect the buyer's rights against the seller under the applicable national legislation, the buyer's rights against the seller as set out in the purchase contract or any other rights. The Terms and Conditions of KTM Fahrrad GmbH apply to commercial users.

Frame, frame kits and rigid forks

When buying a completely assembled bicycle, KTM gives the first buyer a five-year warranty on aluminium frames in regard to material defects and manufacturing faults. This warranty only retains its validity if all maintenance was performed as prescribed in the chapter on *"Maintenance and care instructions"*. KTM also grants a three-year warranty on rigid forks, provided they are KTM products. The terms and conditions of the respective fork manufacturer will otherwise apply.

KTM bicycles and KTM forks made of carbon have a warranty period of three years. The warranty is also restricted to three years for bicycles belonging to category 5 / E5 according to the chapter on *"Intended use"*. The warranty period begins with the date of purchase. It is granted exclusively to the first buyer of a bike from an authorised KTM dealer. The warranty does not extend to purchases made in online auctions.

The aforementioned warranty of five years on aluminium frames and three years on carbon frames and frames in category 5 / E5 according to the chapter on *"Intended use"* only applies if the first inspection is carried out by an authorised KTM dealer after 200 km at the latest and once annually thereafter - refer to the chapter on *"Maintenance and care intervals"*. The authorised KTM dealer must confirm the inspection with their stamp and signature. The warranty period for aluminium frames is shortened from five years to three if this maintenance does not take place.

The costs of inspection and maintenance are incurred by the owner of the KTM bicycle. Frame kits that are purchased from our spare parts department should only be assembled by qualified personnel. Damage due to improper handling or mounting is excluded from warranty claims. In the event of a warranty claim, KTM has the discretionary right to repair the defective component or replace it with one of equal or higher quality. There is no right to an identical colour or design. Components that are not defective will only be replaced on the account of the warranty holder.

Adhere to the instructions in the chapter on *"Intended use"*, which provides information on the maximum permissible weights, types of use and load limits for your KTM bicycle.

Wear parts

Your KTM bicycle is a technical product. Many of the components installed on your bicycle are subject to wear due to their intended function. Wear parts that are damaged by normal use are not covered by the warranty. The following explains and defines the wear parts.

Term	Explanation
Tyres	The frequency with which your bicycle is used, as well as the purposes for which it is used, influence wear of the tyre. The rider can greatly influence tyre wear, e.g. by making sharp braking manoeuvres. Factors such as excessive sunlight, petrol or oils can also damage the tyres – refer to the chapter on <i>“Wheels and tyres”</i> .
Rims in connection with rim brakes	The brake pads and the braking surfaces on the rim are exposed to wear when a rim brake is applied. It is therefore essential to check the rim regularly for its wear status based on defined indicators – refer to the <i>“Brake system”</i> chapter.
Brake pads and brake discs	Care, maintenance and the specific area in which your bicycle is used are crucial factors here. Shorter replacement intervals are necessary if you ride your bicycle in mountainous terrain or for sporting purposes. Check the brake pads and brake discs regularly – refer to the <i>“Brake system”</i> chapter.
Chain	The extent of wear is strongly dependent on the way the bicycle is used. Maintenance and care, for instance cleaning and lubrication, will extend the service life. It is nevertheless necessary to replace the chain when the wear limit is reached – refer to the chapter on <i>“Propulsion”</i> .
Chainrings, sprockets, inner bearings, guide rollers	Maintenance and care, for instance cleaning and lubrication, will extend the service life. A replacement is nevertheless necessary when the wear limit is reached – refer to the chapter on <i>“Propulsion”</i> .
Lighting	The lighting system and reflectors are subject to wear and ageing due to their functions. Regular replacement is nevertheless – refer to the chapter on <i>“Lighting”</i> .
Hydraulic oils and lubricants	Hydraulic oils and lubricants lose their effectiveness over time. Lubrication points should be cleaned and re-lubricated regularly.
Handlebar tape and grips	These components must be replaced regularly.
Shifting system and brake cables	All Bowden cables must be serviced regularly and replaced if necessary. Wear will increase if your bicycle is frequently exposed to the weather.
Paint	Regularly check all painted surfaces for damage. Contact your KTM dealer if necessary. Attach transparent foil onto painted surfaces to prevent the cables from rubbing against the paint.
Stem, handlebars and seat post	The stem, handlebars and seat post are load-bearing components and therefore of vital importance to safety. Have them replaced after 2 years at the latest – refer to the chapter on <i>„Maintenance and care intervals”</i> .

Frame engraving



Carbon frames are not suitable for engraving. It can reduce the stability of the bicycle frame, which may then break when exposed to load. All warranty claims (relating to the frame) would be voided in this case.

Engraving is a common method of theft protection. Nonetheless, particular care must be taken in regard to the guarantee/warranty, as the process will damage the frame to a certain extent. The penetration depth of the engraving must not exceed 0.2 mm, as there will otherwise be problems with warranty claims. The engraving should be placed around the bottom bracket to ensure that frame stability is influenced as little as possible. Contact your KTM dealer if you would like a frame engraving. A transparent sticker that is resistant to environmental influences such as rain, dirt and UV light can be placed over the engraved area to prevent it becoming corroded. An alternative option to engraving the frame is to attach a special sticker with a code that – like with an engraving – is stored in a database and can be retrieved in the case of theft. This method does not damage the frame. Neither of these methods offer complete protection against theft. Ideally, the code should have a deterrent effect on the thief, therefore minimising the cases of actual theft. Always use a tested bicycle lock to secure your bicycle to a fixed object.

Handover Certificate

When taking possession of the bicycle from the buyer, the KTM dealer must ensure that all the points listed below have been checked and that the bicycle was returned in a flawless and safe operating condition. The individual points must be ticked off as soon as they are complete.

Brake check:

- Installation of the brake cables
- Check of the brake cables
- Check of the brake system mounting screws
- Leak test for hydraulic brake systems
- Function and effect of the brakes

Shifting system check:

- Installation of the shift cables
- Shift lever setting
- End stop setting
- Cable tension setting
- Shifting system functions
- Check of the shifting system mounting screws

Chassis check:

- Basic functions and tightness of the suspension fork
- Basic functions and tightness of the shock
- Adjustment and smoothness of the headset
- Check of the mounting screws on the chassis components
- Check of the screw connections on the tail section

Wheel check:

- Trueness check (centring)
- Correct fit of the tyre on the rim
- Check of the spoke tension
- Air pressure in the tyre
- Correct wheel installation
- Tight fit of the quick release
- Tight fit of the thru axle

Other checks:

- Adjustment and tight fit of the handlebars and stem
- Tight fit of the crank and pedals
- Adjustment and tight fit of the saddle, seat post and grips
- Correct riveting of the chain
- Lighting functions
- Adjustment and tight fit of the rack, fender and stand
- Adjustment and tight fit of other mounted parts
- Complete functionality of the e-bike drive unit, including battery charging

When returning the bicycle:

- The bicycle was returned completely and in a flawless and safe operating condition, including the original operating instructions.
- Verbal instructions on correct use of the bicycle were provided, especially on how to run in the brakes.
- Instructions issued by component manufacturers were also handed over.
- The buyer was informed of the importance of adhering to the original operating instructions.
- The buyer was referred to the terms and conditions of warranty in the original operating instructions.

.....
Model

.....
Frame number

.....
Key number

.....
Place and date

.....
Signature of the seller

.....
Signature of the buyer or their parent/guardian

Bicycle registration document

In the event of a warranty claim, a copy of this page or a warranty application must be submitted to us by the KTM dealer from whom you purchased the bicycle. You must therefore keep this bicycle registration document in a safe place.

By signing the document, the KTM dealer warrants that the following bicycle was handed over to the customer ready to use and in a safe operating condition.

Model:

Frame height:

Frame number:

Category (based on intended use):

Permissible maximum weight:

Colour:

Rack permitted: YES NO

Permissible rack load:

Trailer permitted: YES NO

Permissible trailer load:

Child seat permitted: YES NO

Brake system: Rim brake Disk brake

Assignment of the right-hand brake arm: Front wheel brake Rear wheel brake

Assignment of the left-hand brake arm: Front wheel brake Rear wheel brake

Propulsion: Deraillieur gears Shimano hub gears Enviolo shift hub

Wheels and tyres: Thru axle Quick release

Suspension elements: Full suspension Hardtail No suspension

Headset: Bolted Ahead

Wheel:

EPAC drive system:

On-board computer:

Battery:

EPAC battery key number:

Charger:

ABS brake system: YES NO

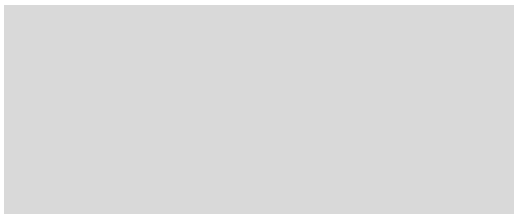

Stamp and signature of the KTM dealer

Inspection Certificate

This document certifies that the bicycle stated model below has been checked for defects by an authorised KTM dealer. Worn parts were replaced and all defects rectified. The bicycle is now in a well-kept and flawless state after servicing.

Name of the buyer:

Model: Date of purchase:

Frame number: Category:

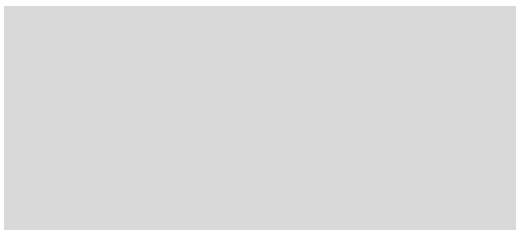

Stamp and signature of the dealer

1. Inspection, after 200 km

2. Inspection, 1-year servicing

Date: Date:

Replaced or repaired parts: Replaced or repaired parts:

.....

.....

.....

.....

.....

.....

.....

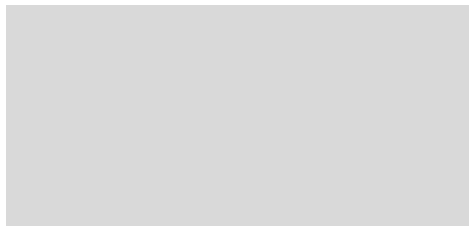

Stamp and signature of the dealer

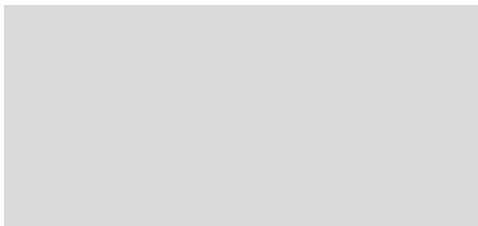

Stamp and signature of the dealer

3. Inspection, 2-year servicing

Date:

Replaced or repaired parts:

.....
.....
.....
.....
.....
.....
.....
.....

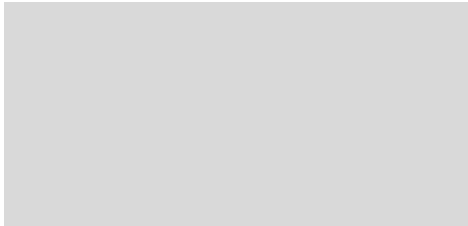

Stamp and signature of the dealer

4. Inspection, 3-year servicing

Date:

Replaced or repaired parts:

.....
.....
.....
.....
.....
.....
.....
.....

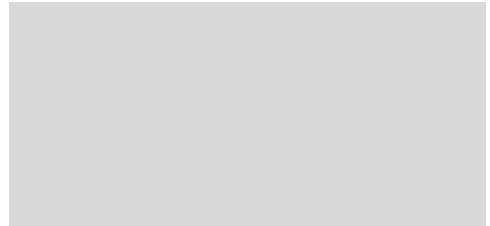

Stamp and signature of the dealer

5. Inspection, 4-year servicing

Date:

Replaced or repaired parts:

.....
.....
.....
.....
.....
.....
.....
.....

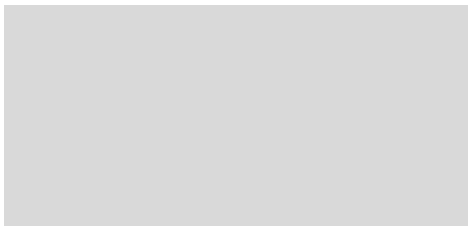

Stamp and signature of the dealer

6. Inspection, 5-year servicing

Date:

Replaced or repaired parts:

.....
.....
.....
.....
.....
.....
.....
.....

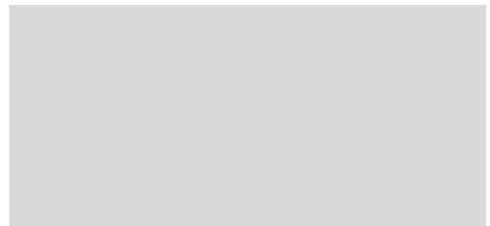

Stamp and signature of the dealer

ktm-bikes.at/service/service-documents



Scanne mich für den Download der Original Betriebsanleitung
Scan me to download the original operating instructions
Scannez-moi pour télécharger le mode d'emploi d'origine
Scansionami per scaricare le istruzioni per l'uso originali
Escanéame para descargar el manual de instrucciones original
Naskenujte mě a stáhněte si originální návod k obsluze
Naskenuj ma pre stiahnutie originálu návodu na obsluhu
Odčitaj me za prenos izvirnika navodil za uporabo
Olvasd be az eredeti használati útmutató letöltéséhez
Zeskanuj mnie, aby pobrać oryginalną instrukcję eksploatacji
Scan mij om het originele instructieboekje te downloaden
Skeniraj me za preuzimanje originalnih uputa za upotrebu
Σάρωσε με για τη λήψη των γνήσιων οδηγιών χρήσης
Ler para descarregar o manual de instruções original
Skanna mig för att ladda ned bruksanvisningen i original
Skannaa ja lataa alkuperäiset käyttöohjeet

KTM
BIKE INDUSTRIES

**KTM FAHRRAD
GMBH**

Harlochnerstraße 13
5230 Mattighofen
Austria

**KTM FAHRRAD
DEUTSCHLAND GMBH**

Adolf-Kolping-Straße 34
D-84359 Simbach am Inn
Germany

DESIGN BY GROUPE-RETORNAIRE

KTM-BIKES.AT

Technische Änderungen ohne weitere Information vorbehalten. Für Irrtümer und Druckfehler keine Haftung. Stand: September 2024
Specifications are subject to change without notice. For errors, technical mistakes and misprints no liability is assumed. Stand: September 2024